

ATMOCVAC



Vacuum Packaging Machine

CYCLONE

User Manual

Art No. 0894516

© Eurodib 2018



- The machine is not suitable for the packaging of toxic, corrosive, irritant or potentially explosive materials.
- All persons responsible for the operation of this machine must at least fully read and understand the chapters about the operation and safety provided in these operating instructions.
- All persons responsible for the assembly, installation, maintenance and/or repairs must fully read and understand these operating instructions.
- The user is at all times responsible for the interpretation and use of this manual. Contact the owner or the manager in case of questions or doubts about the correct interpretation.
- This manual should be kept near the machine and should be within reach for its users.
- All major maintenance work, modifications to the machine and observations must be kept in a logbook; see *Logbook* on page 72.
- Modifications to the installation/machine are not allowed without the prior written consent of the supplier.
- For specific maintenance work not included in this manual, please contact the supplier.
- Comply with the safety requirements as set out in *Safety* on page 8 at all times.
- The correct operation and safety of the system can only be guaranteed if the recommended maintenance is performed on time and properly.
- Illustrations shown may differ from your machine.



Intertek
4010991

Conforms to
ANSI/UL Std. 963
Conforms to
ANSI/NSF 169
Certified to

CAN/CSA Std. C22.2 No.68



Intertek

Copyright © Eurodib 2018

Eurodib reserves the right to change specifications and/or spare parts without prior notice. The content of this user manual may also be changed without prior notice.

For information about settings, maintenance and repairs not provided for in this user manual, please contact the technical department of your supplier.

Eurodib accepts no liability for damage and/or problems arising from the use of spare parts not supplied by Eurodib.

This user manual has been compiled with all possible care. Eurodib assumes no responsibility for any errors in this manual and/or the consequences of an erroneous interpretation of the instructions.

All rights reserved. No part of this publication may be reproduced, stored in computerised databases, or made public, in any form or by any means, either electronic, mechanical, through photocopying, recording or otherwise, without the prior written consent of Eurodib. This also applies to the associated drawings and diagrams.

Contents

List of Figures.....	6
1 Preamble.....	7
2 Safety.....	8
2.1 List of the Symbols Used in this Manual.....	8
2.2 Pictograms on the Machine.....	8
2.3 General Warnings.....	9
2.4 Warnings During Use.....	10
2.5 Warnings for Operating Personnel.....	10
3 Introduction.....	12
4 Description of the Machine.....	13
4.1 Overview of the Main Components.....	13
4.2 Description of the Packaging Process/Machine Functions.....	14
4.2.1 Packaging Process/Machine Functions.....	14
4.2.2 General Functions.....	18
4.3 Sealing System.....	19
4.4 Vacuum Pump.....	20
4.5 Electrical Installation.....	20
5 Installation.....	23
5.1 Transportation and Installation.....	23
5.2 Connecting the Machine.....	23
5.3 Prior to the First Use.....	24
6 Operation.....	25
6.1 Operating Elements of the 10-Program Control System.....	25
6.2 Operating Elements of the Advanced Control System (ACS).....	26
6.2.1 Changing the ACS Settings.....	27
6.2.2 Importing/Exporting Data.....	30
6.2.3 Data Log ID.....	30
6.2.3.1 Setting and Using the Data Log ID.....	30
6.2.3.2 Exporting Data Log.....	31
6.3 Starting the Machine.....	32
6.4 Starting the Packaging Cycle.....	32
6.5 Proceeding to the Next Step in the Cycle.....	32
6.6 Terminating a Program.....	33
6.7 Changing the Program Settings.....	33
6.7.1 10-Program Control System.....	33
6.7.1.1 Vacuum.....	33
6.7.1.2 Vacuum+ (optional).....	34
6.7.1.3 Gas (optional).....	34

6.7.1.4 Gas+ (optional).....	35
6.7.1.5 Liquid Control (optional).....	35
6.7.1.6 Liquid Control+ (optional).....	35
6.7.1.7 Red Meat (optional).....	36
6.7.1.8 Multi-Cycle Vacuum (optional).....	36
6.7.1.9 Seal.....	36
6.7.1.10 Soft-Air	37
6.7.1.11 External Vacuum (optional).....	37
6.7.1.12 Sleeper Option.....	38
6.7.2 Advanced Control System (ACS).....	38
6.7.2.1 Programming the ACS Control Using the PC.....	39
6.7.2.2 Functions.....	40
6.7.2.3 Vacuum.....	40
6.7.2.4 Vacuum+ (optional).....	40
6.7.2.5 Gas (optional).....	41
6.7.2.6 Gas+ (optional).....	41
6.7.2.7 Liquid Control (optional).....	42
6.7.2.8 Liquid Control+ (optional).....	42
6.7.2.9 Red Meat (optional).....	42
6.7.2.10 Sequential Vacuum (optional).....	43
6.7.2.11 Marinating (optional).....	43
6.7.2.12 Tenderising (optional).....	44
6.7.2.13 Seal.....	44
6.7.2.14 Soft-Air	45
6.7.2.15 External Vacuum (optional).....	45
6.7.2.16 Sleeper Option.....	46
6.7.2.17 Dealer Information.....	46
6.8 Guideline for Function Values.....	46
6.9 Printer (ACS only).....	49
6.9.1 Connecting a Printer.....	49
6.9.2 Creating a Label.....	49
7 Maintenance.....	51
7.1 Maintenance Schedule.....	51
7.2 Cleaning the Machine.....	52
7.3 Running the Pump Cleaning Program.....	52
7.4 Removing Oil, Replacing Oil Filter, Refilling Oil.....	52
7.5 Replacing the Oil Exhaust Filter.....	53
7.5.1 Pump 40-300 m ³	54
7.6 Replacing the Sealing Wire.....	54
7.7 Replacing the Silicone Rubber of the Silicone Holders.....	56
7.8 Replacing the Lid Gasket.....	57
7.9 Inspecting the Lid Springs.....	57
8 Troubleshooting.....	59
9 Terms of Warranty.....	61
9.1 Liability.....	61

10 Disposal	62
11 Appendices	63
11.1 Technical Data.....	63
11.1.1 Technical Data Cyclone.....	63
11.2 Example Programs.....	64
11.3 Logbook.....	66
11.4 Replacing a Printer Roll.....	67
11.5 Aligning the Printer.....	68

List of Figures

Figure 1: Overview of the Main Components.....	13
Figure 2: Overview of the Sealing System (Including Sealing Cylinder).....	19
Figure 3: Overview of the Sealing System (Including Seal Bag).....	19
Figure 4: Overview of the Pump.....	20
Figure 5: Overview of the Electrical Installation.....	21
Figure 6: Direction of Rotation of the Vacuum Pump.....	24
Figure 7: Control Panel of the 10-Program Control System.....	25
Figure 8: Control Panel of the Advanced Control System (ACS).....	26
Figure 9: Possible Display Modes.....	27
Figure 10: Possible Display Modes.....	27
Figure 11: Overview of the Menus.....	29
Figure 12: Example of an Exported Data Log.....	31
Figure 13: External Vacuum Adapter Set (10-Program Control System).....	38
Figure 14: Screenshot of the navigation mode and the operating buttons of the ACS.....	39
Figure 15: External Vacuum Adapter Set (ACS).....	45
Figure 16: Vapour Pressure Curve of Water.....	49
Figure 17: Replacing the Oil Exhaust Filter.....	54
Figure 18: Removing the Sealing Bar (Plastic Lid).....	55
Figure 20: Replacing the Sealing Wire.....	55
Figure 21: Replacing the Silicone Rubber of the Silicone Holders.....	56
Figure 22: Replacing the Lid Gasket.....	57
Figure 23: Replacing the Printer Roll.....	66
Figure 24: Aligning the Printer.....	67
Figure 25: Printing the First Label.....	68

1 Preamble

This is the manual for your Eurodib vacuum packaging machine. This manual is intended for anyone who works with or services the machine.

This manual contains information and instructions for installation, operation and maintenance of the machine. We recommend that you carefully read this manual before use and follow the procedures and instructions strictly. This will ensure that you get the best out of the machine and prevents possible accidents and serious injury.

2 Safety

Your vacuum packaging machine has been carefully designed and expertly built to be operated safely. This is corroborated by the EC Declaration of Conformity. However, there are always dangers and safety risks that cannot be eliminated. These dangers and risks are the result of the use functions of the machine and operation of the machine by the user. This section discusses safety instructions and precautions, how they will be pointed out to you and the requirements the user must meet. It is essential that you are well aware of these safety instructions and requirements and observe them at all times!

2.1 List of the Symbols Used in this Manual

For all operations in which the safety of the operator and/or technician is at stake and where caution should be exercised, the following symbols are used.



This symbol provides insight or offers tips to help facilitate certain actions.



This symbol warns for dangerous situations that may lead to damage to the machine or personal injury.



This symbol warns for high voltage.

2.2 Pictograms on the Machine

Pictograms and warnings have been fitted on the machine to warn users of the possible risks.



Warning sign "Hazardous voltage"

- Is located on the back of the machine



Caution sign "Electric Shock"

- Is located on the sealing bars and on the vacuum pump



Caution sign 'Hot surface'

- Is located on the housing of the machine

Warning sign "Gas connection"(optional)



Forbidden to connect oxygen

- Is located on the back of the machine



Warning sign "Gas Connection" (optional)

Maximum allowed gas pressure of the gas flush system

- Is located on the back of the machine



Warning sign "Seal Pressure Connector" (optional)

Maximum allowed gas pressure of the gas flush system

- Is located on the back of the machine



Machine plate

- Is located on the back of the machine



Regularly check whether the pictograms and markings are still clearly recognisable and legible. Replace them if this is not the case.

2.3 General Warnings



- All persons responsible for the operation of this machine must at least fully read and understand the chapters *Safety* on page 8 and *Operation* on page 25.
- Failure to follow or disregard of the safety instructions may result in serious injury.
- Never pack products that can be damaged by vacuum.
- Never vacuum live animals.
- Warranty, ETL Certification and/or liability is void if any damage is caused by repairs and/or modifications that are not authorised by the supplier or any of its distributors.
- In case of malfunction, contact the supplier.
- High pressure cleaning is not allowed. This may cause damage to the electronics and other components.
- Prevent water from entering the ventilation inlet of the chamber or the exhaust of the pump. This causes irreversible damage to the pump.
- The work space around the machine must be safe. The owner of the machine must take the necessary precautions to operate the machine safely.
- It is forbidden to start the machine in an explosive environment.

- The machine has been designed in such a way that production is safe under normal ambient conditions.
- The owner of the machine must ensure that the instructions in this manual are actually complied with.
- The available safety devices may not be removed.
- The correct operation and safety of the system can only be guaranteed if the recommended maintenance is performed on time and properly.
- If work must be carried out on the machine, it must be disconnected and blocked from the power supply and, if applicable, from the air and gas supply.



- Only a technical expert may perform work on the electrical installation.
- Internal procedures and monitoring must be in place to ensure that all relevant power supplies are disconnected.
- The machine may not be used during cleaning, inspection, repair or maintenance and must be disconnected from the power supply by disconnecting the plug and/or using the main switch.
- Never perform welding work on the machine without first disconnecting the cable connection to the electrical components.
- Never use the power supply of the control unit to connect other machines.
- All electrical connections must be connected to the terminal strips according to the wiring diagram.

2.4 Warnings During Use



- Before starting the machine, make sure no work is being performed on the installation and that the machine is ready for use.
- The machine may not be operated by unauthorised persons. This should be monitored by the machine operator(s).
- Immediately contact the service technician of your technical department or dealer if something does not seem right, such as unusual vibrations or unusual noise.
- Components of the sealing system can become very hot. Contact with these components may cause injuries.
- Improper use, such as switching off the machine while it is creating a vacuum, is strongly discouraged. Such actions may cause oil leaking back to the vacuum chamber.

2.5 Warnings for Operating Personnel



- Operating personnel must be 18 years or older.
- Only authorised persons are allowed to perform work on or with the machine.
- Personnel may only perform work for which it was trained. This applies to both maintenance and normal use.
- The machine may only be operated by trained personnel.
- Operating personnel must be familiar with all circumstances, so quick and effective action can be taken in case of an emergency.

- If an operator notices errors or risks or disagrees with safety measures, he or she should report this to the owner or manager.
- Safety shoes are mandatory.
- Appropriate work clothing is mandatory.
- All personnel must obey the safety regulations to avoid danger to themselves and others. Always strictly follow the work instructions.

3 Introduction

Eurodib is a supplier of ultra-modern vacuum packaging machines. Our machines are developed and manufactured to meet the highest standards. They combine a sleekly built and functional design with optimal ease of use and a long service life. After mounting the plug, it is just a matter of "plug & pack". The clever design ensures compliance with the hygiene standards at all times.

The Cyclone series are floor models with various options suitable for a variety of applications. These machines have several programs and options for optimal packaging.

4 Description of the Machine

This section provides an overview of the main components and functions. If detailed information is available in this manual, you will be referred to the specific sections.

4.1 Overview of the Main Components

The figure below shows the main components of the system. The model shown may differ from your machine.

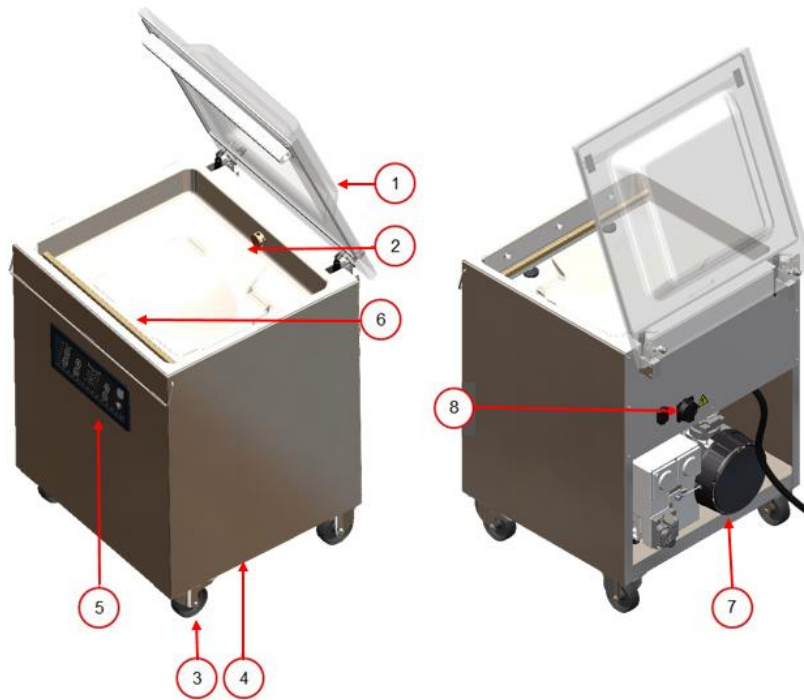

1. Lid

The lid closes the vacuum chamber during the application of the vacuum. A rubber is mounted in the lid to ensure proper closing. On machines with two vacuum chambers, the lid can be moved from position 1 to position 2 manually. In these machines, the sealing bars and suction inlet for the vacuum are included in the lid.

2. Vacuum chamber

The products to be packaged are placed on the work surface with the openings of the vacuum bags on the sealing position. On machines with two vacuum chambers, the already packaged product can be removed and new products can be placed on the free work surface during the vacuuming and sealing process.

3. Castor with brake

The machines are fitted with four castors with brake. This allows for easy moving of the machine to a different location.

4. Machine housing

The machine housing contains all the components necessary for the functioning of the machine.

5. Control panel

This serves to operate the available control functions. Depending on your model, your machine will have the 10-program control system or the Advanced Control System (ACS).

6. Seal system

Depending on the model, one, two or three sealing bars are mounted in the vacuum chamber. These close the vacuum bag.

7. Vacuum pump

The vacuum pump creates the vacuum.

8. Main switch

This serves to switch the machine to the power supply. The machine is supplied without an electrical plug.

4.2 Description of the Packaging Process/Machine Functions

This section provides an overview of the packaging process and available machine functions.



For the functions Liquid Control (and Liquid Control+), Gas (and Gas+), Seal 1-2 Cut-off and Soft-air, specific components must be installed on your machine before they can be enabled. Contact your supplier for more details.













See *Changing the Program Settings* on page 33 for information about setting the parameters to the correct values.



4.2.1 Packaging Process/Machine Functions

This section describes the packaging process and the machine functions. See *Operation* on page 25 for the realization of the specific steps of the procedure.

Step	Process phase	Operation
1.	Preparation	The operator puts the product in a vacuum bag and places it on the work surface with the opening on the sealing position.
2.	Applying vacuum	The vacuum process is initiated by closing the lid. Depending on the options you selected for your machine and the product you are packaging, the following functions are available:





Step	Process phase	Operation
Vacuum		<p>During the cycle, the air is removed from the chamber until the pressure has been reached, depending on the selected model.</p> <p>Applying vacuum until a set value is reached is only possible if your machine is sensor-controlled (optional for 10-program control system). This value can be set in %. The percentage indicates the depth of the vacuum. This is in relation to an outside atmosphere of 0%. In case of the Advanced Control System (ACS), the value is indicated in percentages, mbar or hPa.</p>
Vacuum+		<p>Vacuum+ is only available if the vacuum percentage is set to the maximum.</p> <p>The Vacuum+ option continues the vacuum process for an additional time to allow any entrapped air to escape from the product.</p> <p>The Vacuum+ option is only available on sensor-controlled machines.</p>
Gas (optional)		<p>After applying vacuum, a gas is injected into the package to create a modified atmosphere to protect the shape of the product or to increase the shelf life of the product. The value of the gas function can be set in %, mbar or hPa, depending on the control type of the machine.</p>
Gas + (Optional)		<p>The Gas+ option continues injecting gas during the closing of the bars to increase the amount of gas in the package. See <i>Gas+ (optional)</i> on page 35.</p>
Liquid Control (optional)		<p>Liquid Control is only available if your machine is equipped with the optional Liquid Control sensor.</p> <p>With the Liquid Control option, the system is controlled by a highly sensitive sensor. The sensor is able to detect the moment that liquids from the product or the product itself begin to evaporate (boil). At that time the system will proceed to the next step in the process. This will prevent the product from dehydrating, losing weight and/or the vacuum bag from</p>

Step	Process phase	Operation
		bursting, thus contaminating the seal, the chamber, and the oil in the pump. See <i>Liquid Control (optional)</i> on page 35.
	Liquid Control+ (optional)	Liquid Control+ is only available if your machine is equipped with the Liquid Control option. The Liquid Control+ function allows you to continue the vacuum process for a certain time after the evaporation point has been reached.
		
	Red meat (optional)	This option is especially designed for the packaging of fresh meat. It is added to the normal vacuum function to prevent degassing of the product during and after the sealing phase. This degassing could create air pockets inside the package. See <i>Red Meat (optional)</i> on page 36.
		
	Sequential Vacuum (optional)	This function is only available on machines with the Advanced Control System (ACS). With sequential vacuum, you can alternate vacuum and pause steps to allow air trapped inside a product to escape from the core. A maximum of 5 steps can be programmed.
		
	Multi-Cycle Vacuum (optional)	This function is only available on machines with a 10-program control system. See <i>10-Program Control System</i> on page 33. The Multi-Cycle Vacuum option allows you to vacuum and insert gas in steps. This provides an additional reduction in the oxygen content.
		
	Marinating (optional)	This function is only available on machines with the Advanced Control System (ACS). This function is especially designed to accelerate the marinating of a product. This program allows definition of up to 5 vacuuming steps with intermediate ventilation steps. The vacuuming steps have a fixed vacuum value of 80%, except for the last step. The last vacuuming step has an adjustable value of up to 99.8%. This also allows setting
		

Step	Process phase	Operation
		<p>Vacuum+. The intermediate ventilation steps have a fixed value of 42%. After the last step, sealing takes place.</p> <p>Liquid Control: It is also possible to enable Liquid Control. This function will then only be active during the last vacuuming step. If, for instance, 3 vacuuming steps have been defined, Liquid Control will be active during the third step. Vacuum+ is also possible here; however, this would be a Liquid Control+ setting of 0.1 sec with a maximum of 5.0 sec.</p>
	<p>Tenderising (optional)</p> 	<p>This function is only available on machines with the Advanced Control System (ACS).</p> <p>This feature has been designed to keep the chamber at a pre-determined vacuum level for a certain time. This is done to tenderise or degas the product.</p> <p>During the cycle, the air is removed from the chamber until the pre-set value has been reached. Once this value has been reached, the chamber will remain at this vacuum level for the pre-set time.</p>
3.	Sealing	The sealing bars are pressed against the vacuum bag and melt the bag closed.
	<p>Seal</p> 	<p>During the sealing process, the material of the vacuum bag is heated and pressed together to create a hermetic seal. The programming of this function takes place in seconds.</p> <p>Optionally, a cut-off wire is available. The purpose of the cut-off wire is to remove the excess foil. Depending on the selected model, the cut-off wire is controlled simultaneously with or independent from the sealing wire (Seal 1-2 cut-off).</p>
4.	Decompressing	The vacuum is removed from the vacuum chamber by letting air into the chamber.
	<p>Soft-Air (optional for the Falcon)</p> 	<p>This function allows air from outside to slowly enter the chamber so the vacuum bag will shape itself slowly around the product. This prevents sharp edges of the product from puncturing the foil and causing leaks.</p>
5.	Opening the vacuum chamber	The lid opens.

Step	Process phase	Operation
6.	Removing the product	The operator can remove the packaged product from the work surface.

4.2.2 General Functions

Function	Pictogram	Operation
Cleaning of the oil pump		The pump cleaning program ensures that the pump is thoroughly rinsed. During the program, the pump and oil reach the operating temperature, so the oil and moisture are separated and any contamination is filtered. The high temperature causes any moisture in the pump to evaporate, thus minimising the risk of corrosion.
Menu		This menu is available on machines with ACS control. The menu is used to change the machine settings, such as language and print options.
Printing		<p>This function is available on machines with ACS control.</p> <p>This function allows the creation of one or more labels per cycle, to be put on the packaging.</p> <p>The following information can be printed on the label: name of the producer, name of the product, production date, shelf life, achieved vacuum, initials of the user, recommended storage temperature and an information field (for example to indicate the gas used).</p>
External Vacuum		<p>This function is available as an option, depending on the type of machine.</p> <p>This function allows special food containers to be vacuumed outside the machine.</p> <p>The options to set the vacuum value are the same as for standard vacuuming (see <i>External Vacuum (optional)</i> on page 37 for 10-program control system or <i>External Vacuum (optional)</i> on page 45 for ACS control).</p>
Sleeper option		The Sleeper option shuts down the machine after a certain time. The default setting is 10 minutes. If you wish to change this time, please contact your supplier.

4.3 Sealing System

The sealing system closes the opening(s) of the bag to retain the vacuum and/or gas in the bag. The end of the bag can optionally be cut off by the sealing bar.

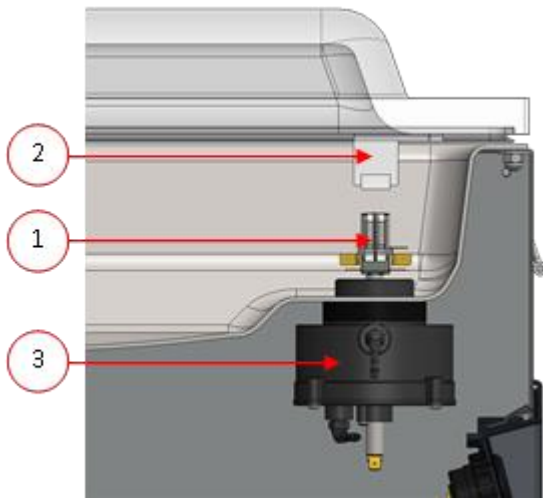

Figure 2: Overview of the Sealing System (Including Sealing Cylinder)

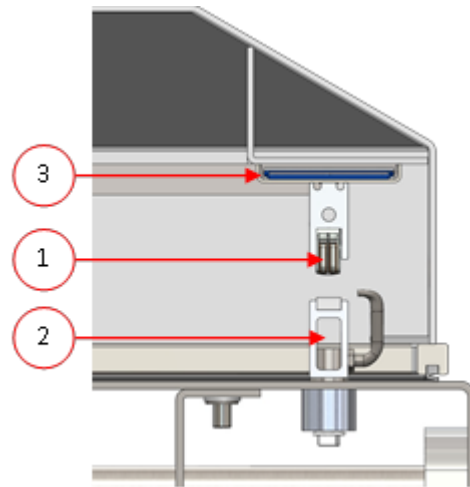

Figure 3: Overview of the Sealing System (Including Seal Bag)

1. Sealing bar

The sealing bar consists of the following components:

- Sealing wires: during the sealing process, the sealing wires are heated for a certain time causing the edges of the vacuum bag to melt together.
- Cut-off wires (optional): A cut-off wire is heated in such a way that the foil of the bag partially melts, allowing the excess foil of the vacuum bag to be removed easily.
- Teflon tape: sealing and cut-off wires are covered with Teflon tape to prevent the bag from sticking to the sealing bar.

Consult *Replacing the Sealing Wire* on page 54 for more detailed information about maintenance.

2. Silicone holder

Opposite the sealing bar is a silicone holder which provides counterpressure on the cylinders/ seal bag (*Replacing the Silicone Rubber of the Silicone Holders* on page 56).

3. Sealing mechanism

The sealing bars are pressed onto the vacuum bag by bellows or cylinders.

By connecting the inlet of the bellows or cylinders with the atmospheric pressure outside, they press the sealing bar onto the bag.

Additional sealing pressure (optional) may, depending on the model you have, be used if additional pressure force is needed.

See *Technical Data* on page 63 and *Connecting the Machine* on page 23 for more information.

4.4 Vacuum Pump

The vacuum pump creates the vacuum.

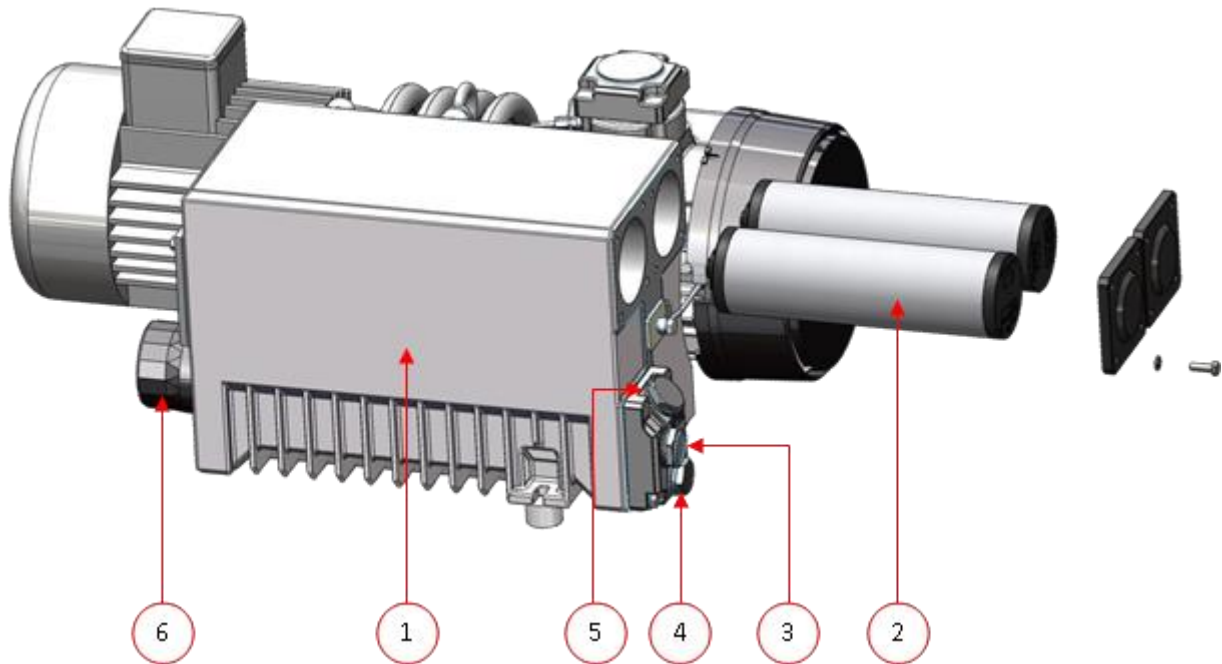

Figure 4: Overview of the Pump

1. **Vacuum pump** - Creates the vacuum for the process.
2. **Oil exhaust filter** - Filters the air by capturing oil vapours.
3. **Oil sight glass** - Indicates the maximum and minimum oil levels of the vacuum pump.
4. **Oil drain plug** - Removing the oil drain plug allows the oil to be drained.
5. **Oil filler plug** - Removing the oil filler plug allows the oil to be refilled.
6. **Oil filter** - Filters the oil.

4.5 Electrical Installation

The electrical installation provides power for the vacuum pump, the seal system and the operation of the machine.

See the electrical diagram for the further structure and operation of the electrical installation. Please contact your supplier for the electrical diagram.



Only a technical expert may perform work on the electrical installation.

The machine consists of the following electrical components:

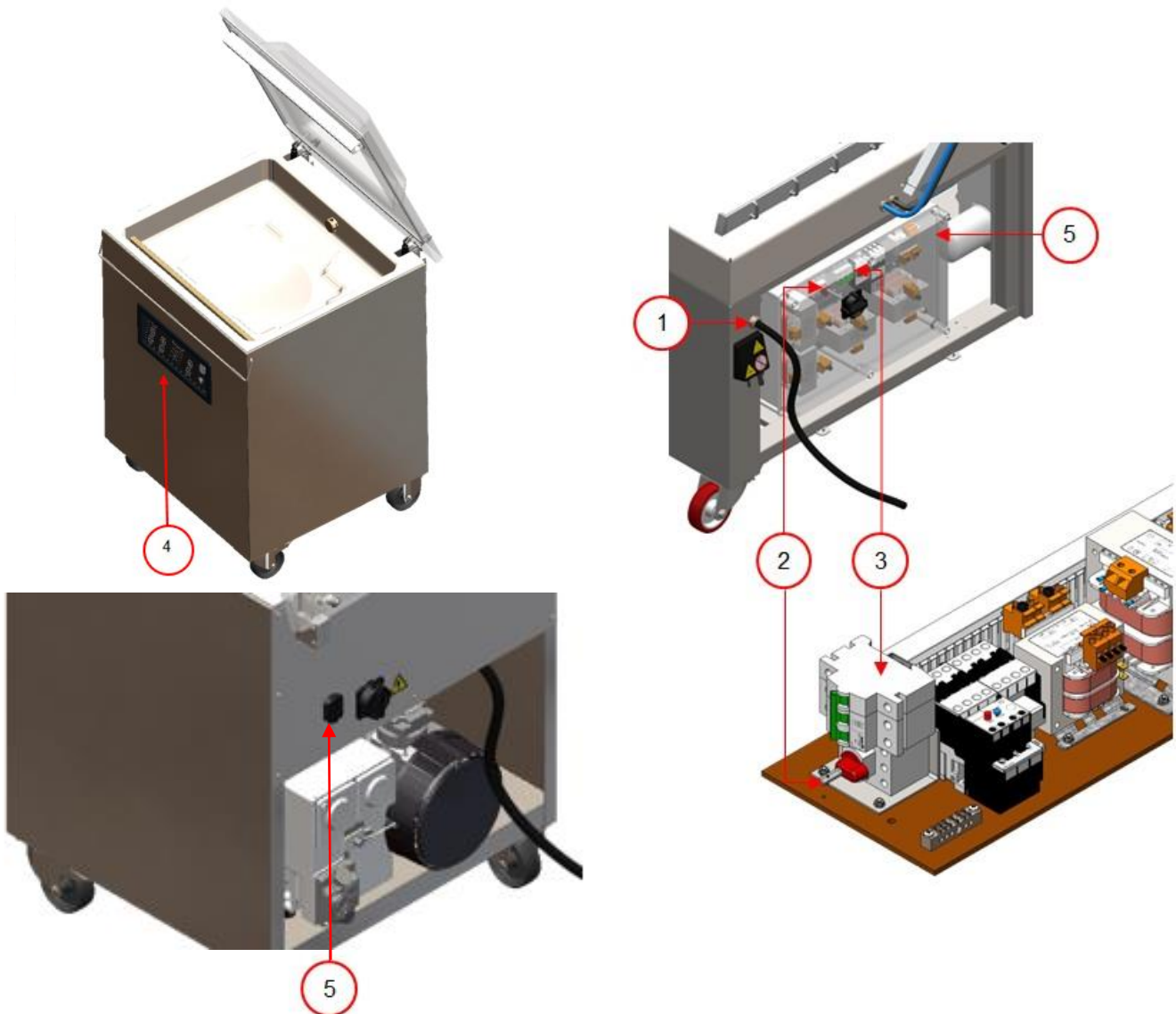

Figure 5: Overview of the Electrical Installation

1. Power connection and cable

This serves to connect the machine to the power supply. The machine is supplied without an electrical plug.

2. Main switch

This switch is used to switch the machine ON and OFF.

3. Circuit breaker

Protects against overload or a short circuit. Also see *Troubleshooting* on page 59.

4. Control panel

This serves to operate the control functions. Depending on your model, your machine will have one of the following control options:

- *Operating Elements of the 10-Program Control System* on page 25
- *Operating Elements of the Advanced Control System (ACS)* on page 26

5. USB connector (only in case of ACS control)

The USB connector is located on back of the machine.



After opening the cover of the USB connector, the machine is no longer waterproof (IP65).

The USB connector enables the import and export of data.

5 Installation

Consult *Technical Data* on page 63 for the specifications of the machine.



Before installing the machine, carefully read the safety instructions in *Safety* on page 8. Failure to follow or disregard of the safety instructions may result in serious injury.

5.1 Transportation and Installation

The machine must be moved and transported in an upright position.

The machine may not be transported using a crane. The machine may be transported with a forklift provided it is still on the pallet packaging.

Moving the machine on wheels on uneven surfaces may lead to loss of stability of the machine. Always move the machine slowly and carefully.

1. Place the machine on a flat, level surface. This is essential to ensure a trouble-free operation of the machine.



Do not position machines with plastic covers in the vicinity of a heat source.



Make sure there is sufficient space (at least 50 cm) around the machine to ensure a proper ventilation.

2. Ensure the brakes of the machine are activated.
3. Verify that the machine housing is present and correctly fitted.

5.2 Connecting the Machine

1. Make sure the power supply for this machine matches to the voltage and amperage stated on the machine plate. Note specified amperage: 16 /fuse 20 C. The first value is the nominal amperage and the second value the minimum fuse value with the recommended type of fuse. The C stands for a C characteristic. If you have questions and / or comments about this, contact your supplier prior to installation.
2. Fit the correct plug on the cable in accordance with local legislation and connection data. See *Technical Data* on page 63.
3. Fit the connecting cable to the machine. See *Technical Data* on page 63.
4. Connect the machine to a grounded wall outlet to avoid fire or electric shock (the earth connection is green/yellow).



The power cable must be free at all times, and nothing may be placed on it. Immediately replace the power cable if damaged.

5. Check the correct direction of rotation of the three-phase model pump. See *Figure 6: Direction of Rotation of the Vacuum Pump* on page 24.

Operating the machine with an incorrect direction of rotation results in damage to the pump, in which case no vacuum can be created. After connecting the machine to a different three-phase power supply, the direction of rotation should be checked again. If the direction of rotation is incorrect, two phases in the plug must be interchanged.



Only a technical expert may perform work on the electrical installation.

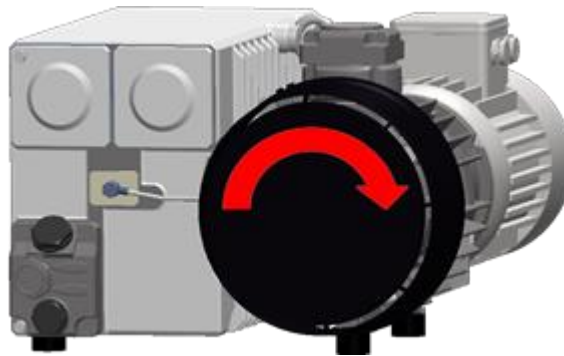

Figure 6: Direction of Rotation of the Vacuum Pump

6. Optional: Connect the gas supply for the gas flush system.
7. Optional: Connect the air supply for additional sealing pressure.

5.3 Prior to the First Use

1. Check the oil sight glass to see if the amount of oil in the pump is sufficient.
2. Optional: If the amount of oil in the pump is insufficient, refill it. See *Removing Oil, Replacing Oil Filter, Refilling Oil* on page 52.
3. Proceed with *Starting the Machine* on page 32 to start up the machine.

6 Operation

The machine is equipped with sample programs with preset parameters (see *Example Programs* on page 70).

It is possible to optimise a program for your products by modifying the parameters of a program, see *Changing the Program Settings* on page 33.



- All persons responsible for the operation of this machine must at least fully read and understand the chapters *Safety* on page 8 and *Operation* on page 25.
- Failure to follow or disregard of the safety instructions may result in serious injury.

6.1 Operating Elements of the 10-Program Control System

The 10-program control system allows the machine to be operated and programs to be changed.

See *Operation* on page 25 for instructions on the operation and programming.

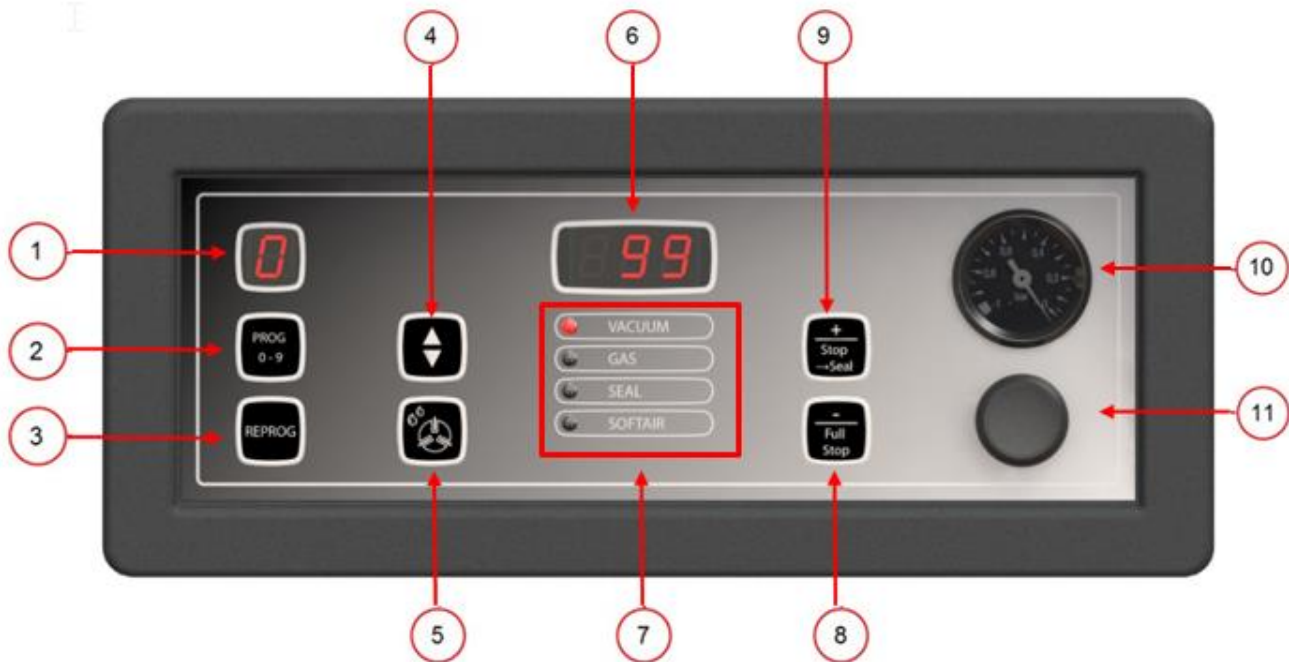

Figure 7: Control Panel of the 10-Program Control System

- 1. Program display**
Shows the selected program.
- 2. PROG 0 – 9 button**
This is used to select the desired program.
- 3. REPROG button**
This is used to enable the programming mode. The parameters can be changed using the **Cursor key**, the **- / STOP** button and the **+ / VACUUM STOP** button.
- 4. Cursor key**
This key is used to operate the functions of the parameter display and function display.

5. Pump cleaning program button

This is used to activate the pump cleaning program. Moisture can be absorbed by the oil when the pump is running only short cycles or when you are packaging moisture-containing products. This program removes moisture from the oil of the vacuum pump. See *Running the Pump Cleaning Program* on page 52 for instructions.

6. Parameter display

This display shows the current value of the active function during the program cycle or the set value of the selected function when the machine is inactive. A red dot will light up in the bottom right if the Vacuum+ option is enabled.

7. Function display

The LED light in front of the function lights up if the function is active during the program cycle or if the function is selected in the programming mode.

8. - / STOP button

This is used to interrupt the entire cycle during a packaging cycle. All functions are skipped and the cycle is terminated. In the programming mode, the value of the selected parameter can be lowered using this button.

9. + / VACUUM STOP button

This stops the active function and proceeds to the next program step. In the programming mode, the value of the selected parameter can be increased using this button.

10. Vacuum meter

Shows the pressure in the vacuum chamber. A value of -1 bar corresponds to 99% vacuum.

11. On/Off button

Serves to turn the control panel on or off.

6.2 Operating Elements of the Advanced Control System (ACS)

The ACS control panel allows the machine to be operated and programs to be changed.

See *Operation* on page 25 for instructions on the operation and programming.

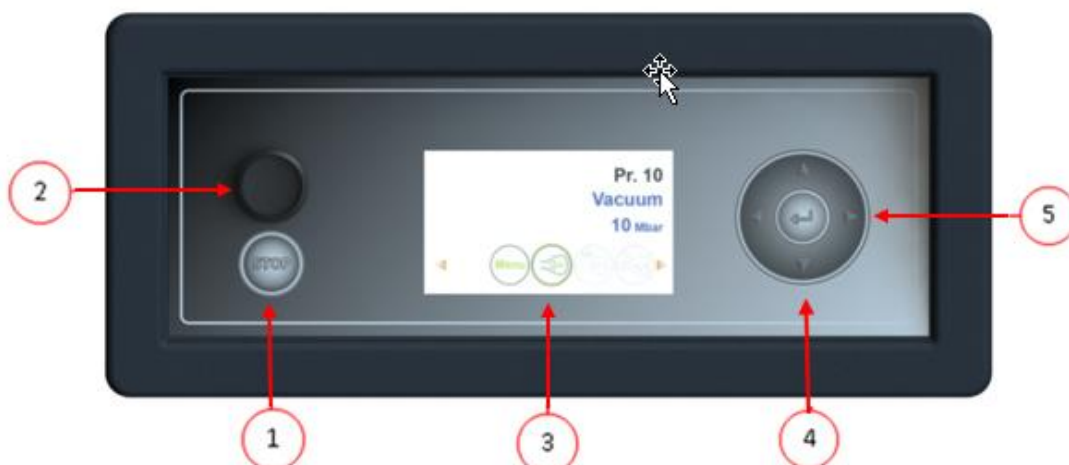

Figure 8: Control Panel of the Advanced Control System (ACS)

1. STOP button

This is used to interrupt the entire cycle during a packaging cycle. All functions are skipped and the cycle is terminated.

2. On/Off button

Serves to turn the control on or off.

3. Display

The display has four possible modes: See *Figure 9: Possible Display Modes* on page 27 and *Figure 10: Possible Display Modes* on page 27.

- **Start-up mode:** displays the current date and time when starting the machine. It also displays the installed software version. The user cannot take any action.
- **Navigation mode:** displays a program and its functions. The user can navigate through the various programs and view the current settings of each function.
- **Setting mode:** the user can view and adjust all settings, provided the user is logged in as the owner.
- **Cycle mode:** once the machine starts a packaging cycle, animations of the functions are displayed along with the current value of the function.

4. Cursor keys ▲, ▼, ◀ and ▶

These are used to navigate through the functions. The ▶ button stops the active function and proceeds to the next cycle step. See *Proceeding to the Next Step in the Cycle* on page 32.

5. Enter

This activates/confirms the selected value.

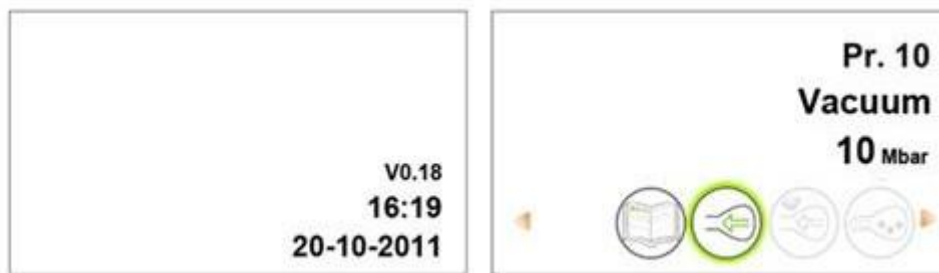

Figure 9: Possible Display Modes

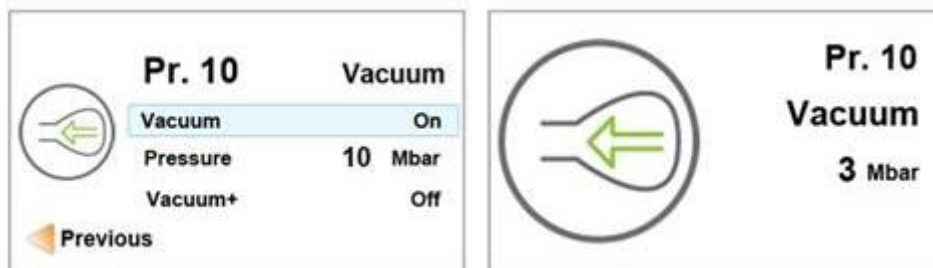

Figure 10: Possible Display Modes

6.2.1 Changing the ACS Settings

To prevent unauthorised changing of the settings and adjustments, there are different levels of authorisation: user and owner. Authorisation codes for users or owners allow access to the various levels. User access to change the settings of the machine is limited. The default user code is 0000. Users can only activate the printer via the printer icon in the navigation mode.

Owners of the machine are authorised to change the machine settings as well as all function settings. An owner code is requested when the menu icon is selected in navigation mode. This owner code is 1324. When the owner code has been entered, the machine settings menu will

be opened. When logged in, the function settings can also be changed. To do so, return to the navigation mode by pressing ◀.



The machine remembers the last authorisation code used, even when the machine has been turned off. Therefore, it may be necessary to manually change the authorisation setting when you are done.

The basic functions below allow you to adjust the machine and/or function settings:

What to do?	Action
Selecting a different setting	Press ▲ or ▼.
Editing the selected setting	Press Enter .
Adjusting a variable	Press ▲ or ▼.
Conforming a variable	Press Enter once the desired variable has been found.
Return to the navigation mode	Press ◀ when all settings have been set to return to the navigation mode.



Figure 11: Overview of the Menus on page 29 shows all possible settings for all functions.

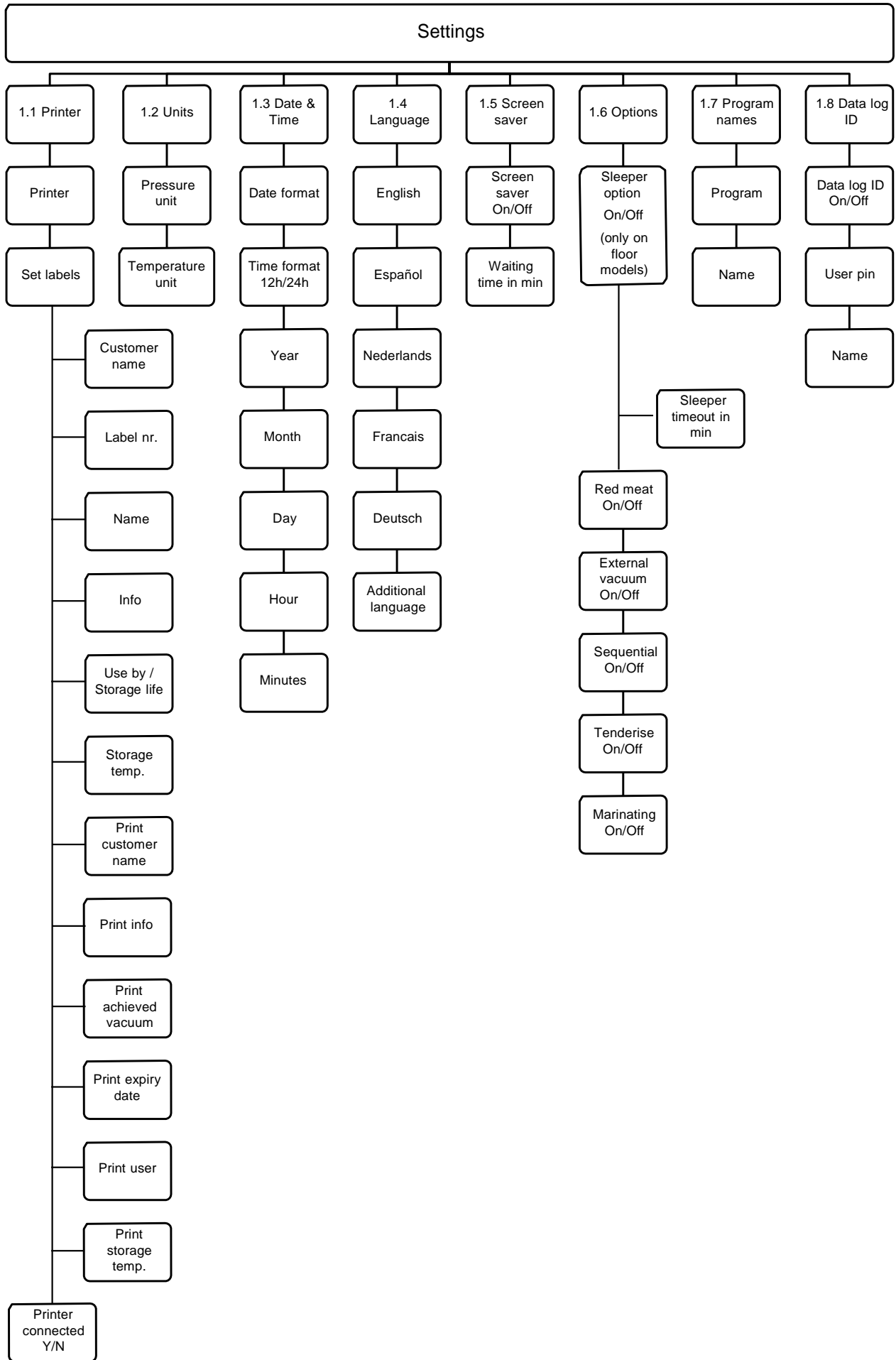

Figure 11: Overview of the Menus

6.2.2 Importing/Exporting Data

Data such as programs and labels can be imported and exported via the USB connection.

6.2.3 Data Log ID

The control system is provided with the option to store the production information. The data log is stored in lined entries. Each entry consists of:

- Date
- Time
- User initials
- Selected program and settings
- Selected label
- Number of cycles

A new entry is stored when:

- A different user logs in.
- The program or program settings are changed.

The data log is stored as a .txt file. You can then export the data log to a USB stick, see *Exporting Data Log* on page 31.

6.2.3.1 Setting and Using the Data Log ID

This setting is disabled by default. This option can be enabled after logging in using the owner code. 5 possible users can be set:

- Owner
- Four other users:
 - User 2: 3821
 - User 3: 5718
 - User 4: 6982
 - User 5: 9217

1. Log in using the owner code (1324).
You will be granted access to the relevant settings.
2. Within the menu, go to **Settings > Data log ID** and select **ON**.
From this moment on, the data will be logged.
3. Assign initials to the user codes (maximum 2 characters).
 - a. At **User**, select the desired user code.
 - b. Enter the initials of the user at **Name**.The initials of the user will be displayed in the data log.



The initials of the user must be set. If this is not the case, it cannot be traced who operated the machine.

6.2.3.2 Exporting Data Log

The memory can store up to 100 entries. If the memory is full, you will receive a message. The data log will first need to be exported before you can continue your work. You can export the data at any time. Only the owner can export data. After exporting the data, the memory will be erased automatically.



Avoid undesired delay during production by downloading the data log at fixed times.

1. Log in using the owner code (1324).
You will be granted access to the relevant settings.
2. Within the menu, go to **Import/Export** and select **Export**.
3. Insert a USB stick into the USB port.
Various options will appear on the screen.
4. Select **Export Data log**.
The log will be downloaded to the USB stick and the memory is erased.

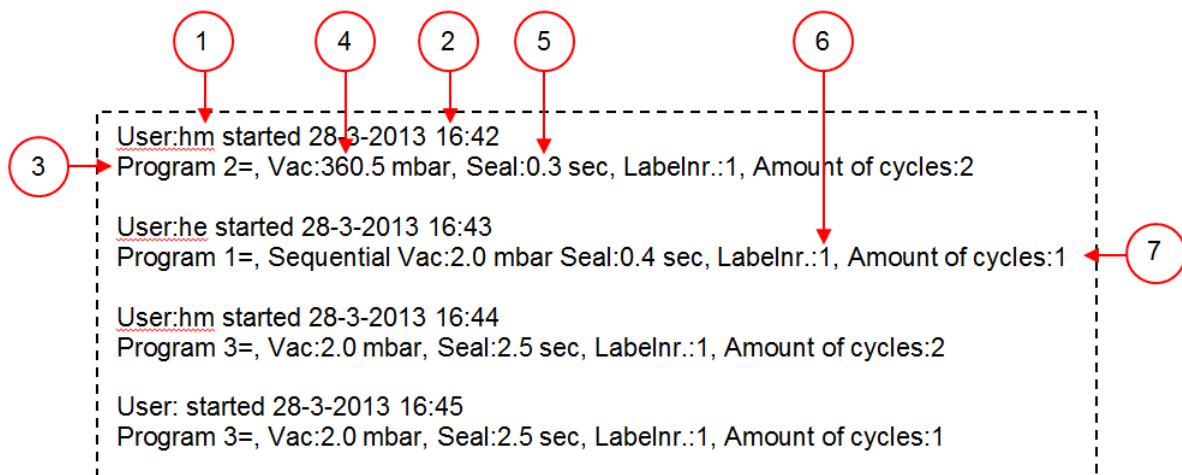

Figure 12: Example of an Exported Data Log

1. **User Initials**
The initials of the person who logged in. If no initials were entered in the settings, nothing will be shown here. See the example in the bottom line of *Figure 12: Example of an Exported Data Log* on page 31.
2. **Start Time and Date**
Start time and date of the production.
3. **Program**
The program number used.
4. **Vacuum**
The maximum achieved vacuum of the package.
5. **Seal Time**
The seal time used.

6. Label Number

The label that was printed for this package.

7. Number of Cycles

The number of cycles run from the start time.

6.3 Starting the Machine

1. Plug in the machine.
2. Turn the main switch to the ON position (see *Electrical Installation* on page 20) to turn on the machine.
3. Press the on/off button on the control panel to enable the operation.

In the 10-program control system, 3 dashes may be shown on the display during the first start-up or ventilation. This means that the machine needs to be decompressed. In this case, open the lid to decompress the machine.

6.4 Starting the Packaging Cycle

The machine must be started in accordance with *Starting the Machine* on page 32 before starting a packaging cycle.

1. Select the desired program.

10-program control system Press the **PROG 0 – 9** button.

ACS Press the ► button or the ▼ button.

2. Put the product/products in place.
 - a. Put the product/products in the vacuum bag.
 - b. Place the vacuum bag in/on the vacuum chamber. Make sure the opening(s) is/are correctly placed with regard to the seal position(s).
3. Close the lid.

The packaging cycle will start.

6.5 Proceeding to the Next Step in the Cycle

For some products, it may be necessary to proceed to the next step in the packaging cycle before the vacuum time or the vacuum level has been reached.

1. Proceed to the next step in the cycle.

10-program control system Press the **+ / VACUUM STOP** button.

ACS Press the ► button.

The next step will be started.

6.6 Terminating a Program

Programs such as the packaging program or the pump cleaning program can be terminated at any time.

1. Terminate the program.

10-program control system Press the **- / STOP** button.

ACS Press the **STOP** button.

The program will be terminated and the vacuum chamber is decompressed.

6.7 Changing the Program Settings

6.7.1 10-Program Control System

10 programs are available. Programs 1 – 9 can be adjusted by the user. Program 0 is intended for servicing purposes only. This section describes the units and limits of the parameters and how parameters can be adjusted.

See *Operating Elements of the 10-Program Control System* on page 25 for an overview of the operating elements of the 10-program control system.

1. Press the **PROG 0 – 9** button to select the program you wish to change.
2. Press the **REPROG** button to select the programming mode.
The function display will start flashing.
3. Use the **Cursor key** to scroll to the desired parameter.
The LED in front of the selected function will light up.
4. Press the **- / STOP** button and the **+ / VACUUM STOP** button to adjust the value.
5. Press the **REPROG** button to activate the new parameter.
The function display will stop flashing.

6.7.1.1 Vacuum

During the cycle, the air is removed from the chamber until the set pressure has been reached, depending on the selected model (time-controlled or sensor-controlled).

1. Press the **PROG 0 – 9** button to select the program for which you wish to set the Vacuum option.
2. Press the **REPROG** button to select the programming mode.
The function display will start flashing.
3. Use the **Cursor key** to scroll to the parameter Vacuum.
The LED in front of the selected function will light up.
4. Press the **+ / VACUUM STOP** button or **- / STOP** button to adjust the value.
5. Press the **REPROG** button to activate the new parameter.
The function display will stop flashing.

6.7.1.2 Vacuum+ (optional)

If air is trapped in the product, it may be desirable to extend the vacuuming time after the maximum vacuum has been reached. This to allow entrapped air to escape from the product.

The Vacuum+ time is set in seconds. If a Vacuum+ time has been set, a dot will appear in the bottom right of the parameter display.

1. Press the **PROG 0 – 9** button to select the program for which you wish to set the Vacuum+ option.
2. Press the **REPROG** button to select the programming mode.
The function display will start flashing.
3. Use the **Cursor key** to scroll to the parameter Vacuum.
The LED in front of the selected function will light up.
4. Press the **+ / VACUUM STOP** button to adjust the value to maximum.
5. Press the **Cursor key** once to select the Vacuum+ parameter.
The parameter display indicates OFF. The LED of the function display will remain on Vacuum.
6. Press the **- / STOP** button and the **+ / VACUUM STOP** button to adjust the value of Vacuum+.
When setting a value, a dot will appear in the bottom right of the parameter display.
7. Press the **REPROG** button to activate the new parameter.
The function display will stop flashing.

6.7.1.3 Gas (optional)

For the protection of the product, it may be desirable to insert a gas into the packaging after vacuuming. Optionally, the machine can be equipped with a gas flush system.

See *Technical Data* on page 63 for the connection details.



Never use a gas mixture containing more than 20% oxygen or other explosive gases. This may cause life-threatening explosions.



The insertion of gas lowers the seal pressure. The minimum final pressure (after the insertion of gas) must be 30% (300 mbar/0.3 on vacuum meter) to ensure proper sealing.

1. Press the **PROG 0 – 9** button to select the program for which you wish to set Gas.
2. Press the **REPROG** button to select the programming mode.
The function display will start flashing.
3. Use the **Cursor key** to scroll to the parameter Gas.
The LED in front of the selected function will light up.
4. Press the **+ / VACUUM STOP** button to adjust the value.
5. Press the **REPROG** button to activate the new parameter.
The function display will stop flashing.

6.7.1.4 Gas+ (optional)

The Gas+ option only applies if the machine is equipped with the gas option. For some products it may be desirable to insert additional gas into the packaging to create a "balloon packaging". This allows for a better protection of a fragile product. The recommended value for Gas+ is 0.7 seconds.

If the Gas+ option is enabled, a dot will appear in the bottom right of the program display. If the Gas + option is enabled, this will apply to all programs for which gas has been set.

To enable the Gas+ option on your machine, please contact your supplier.

6.7.1.5 Liquid Control (optional)

The Liquid Control option can be enabled or disabled for each program. If the Liquid Control option is enabled, the machine will vacuum until the maximum vacuum is reached (99%). If the product reaches the boiling point before the maximum vacuum is reached, the machine will proceed to the next step of the cycle.

1. Press the **PROG 0 – 9** button to select the program for which you wish to set Liquid Control.
2. Press the **REPROG** button to select the programming mode.
The function display will start flashing.
3. Press the **PROG 0 – 9** button until H2O is shown on the parameter display.
The parameter display indicates H2O.
4. Press the **REPROG** button to activate the new parameter.
The function display will stop flashing.

The Liquid Control function prevents excessive fluid from being drawn out of the product. This means that if the product reaches the boiling point, the machine will proceed to the next step of the cycle. Depending on the moisture content, the manner in which moisture is bound, the available surface for evaporation and the temperature, the end vacuum percentage might be limited and there might be too much residual oxygen content present in the package. If the product/process requires packaging with a low residual oxygen content, despite the high moisture content, there are two options:

1. Lower the product temperature. This allows for a deeper vacuum to be reached before the product reaches the boiling point.
2. Use the Liquid Control+ option.

6.7.1.6 Liquid Control+ (optional)

The Liquid Control+ time is set in seconds. This is the time the vacuuming will continue after detection of the evaporation point.

You can only set Liquid Control+ if Liquid Control has been set to the maximum. To set the Liquid Control+ option, follow the steps below:

1. Press the **PROG 0 – 9** button to select the program for which you wish to set Liquid Control+.
2. Press the **REPROG** button to select the programming mode.
The function display will start flashing.
3. Press the **PROG 0 – 9** button until H2O is shown on the parameter display.
The parameter display indicates H2O.
4. Press the **Cursor key** once to select the Liquid Control+ parameter.
The parameter display indicates OFF. The LED of the function display will remain on Vacuum.

5. Press the **- / STOP** button and the **+ / VACUUM STOP** button to adjust the value of Liquid Control+.
When setting a value, a dot will appear in the bottom right of the parameter display.
6. Press the **REPROG** button to activate the new parameter.
The function display will stop flashing.

6.7.1.7 Red Meat (optional)

The Red Meat option is especially designed for the packaging of fresh meat. Degassing the product during the vacuuming process may result in the formation of air pockets inside the package. The Red Meat option prevents degassing of the product during and after the sealing phase.

The Red Meat option can be set for each program individually. If the Red Meat option is enabled in a program, it will not be possible to enable the Soft-air option in that program.

When selecting this option, a parameter to set the "expansion reduction time" will appear. This is indicated by a flashing LED in front of the Soft-air option in the function display. It is recommended not to change this setting. Please contact your supplier for this.

To enable the Red Meat option on your machine, please contact your supplier.

6.7.1.8 Multi-Cycle Vacuum (optional)

The Multi-Cycle Vacuum option allows you to vacuum and insert gas in up to 5 steps. This provides an additional reduction in the oxygen content. This function is useful only for very specific applications, which set very special demands on the residual oxygen content or the maximum allowed vacuum. This option will not result in any appreciable benefit in the food industry.

To enable the Multi-Cycle Vacuum option on your machine, please contact your supplier.

1. Press the **PROG 0 – 9** button to select the program for which you wish to set Multi-Cycle.
2. Press the **REPROG** button to select the programming mode.
The function display will start flashing.
3. Use the **Cursor key** to scroll to the parameter Vacuum.
The LED in front of the selected function will light up.
The right-side character of the parameter display indicates which vacuuming step you are programming.
4. Press the **- / STOP** button and the **+ / VACUUM STOP** button to adjust the value of Vacuum.
5. Use the **Cursor key** to scroll to the parameter Gas.
The LED in front of the selected function will light up.
6. Press the **- / STOP** button and the **+ / VACUUM STOP** button to adjust the value of Gas.
7. Repeat steps 3 and 4 if an additional vacuuming step is desired.
8. Press the **REPROG** button to activate the new parameter.
The function display will stop flashing.

6.7.1.9 Seal

This is the time that the sealing wire and/or the cut-off wire are heated. The longer the time, the more heat is transferred to the bag.

As an option, the machine can be equipped with a Seal 1-2 option. This means the seal wire is activated separately from the cut-off wire. This way the cut-off wire can be activated a bit longer, to cut through thicker bags.

To set the Seal option, follow the steps below:

1. Press the **PROG 0 – 9** button to select the program you wish to change.
2. Press the **REPROG** button to select the programming mode.
The function display will start flashing.
3. Use the **Cursor key** to scroll to the parameter Seal.
The LED in front of the selected function will light up.
4. Press the **- / STOP** button and the **+ / VACUUM STOP** button to adjust the value.
5. Press the **REPROG** button to activate the new parameter.
The function display will stop flashing.

To change the Cut-off time:

6. Press the **Cursor key** again. The LED in front of Seal will still be lit. Repeat steps 4 and 5.

6.7.1.10 Soft-Air (optional for the Falcon)

This is the time that air is softly released into the chamber after sealing has taken place.

To set the Soft-air function, follow the steps below:

1. Press the **PROG 0 – 9** button to select the program you wish to change.
2. Press the **REPROG** button to select the programming mode.
The function display will start flashing.
3. Use the **Cursor key** to scroll to the parameter Soft-air.
The LED in front of the selected function will light up.
4. Press the **- / STOP** button and the **+ / VACUUM STOP** button to adjust the value.
5. Press the **REPROG** button to activate the new parameter.
The function display will stop flashing.

6.7.1.11 External Vacuum (optional)

The External Vacuum function allows special food containers to be vacuumed outside the machine. Depending on whether the machine is time or sensor-controlled, the vacuum value is set in seconds or %.

External Vacuum is only available on the Cyclone series.

With the External Vacuum program, you can program as with any other program. See *Changing the Program Settings* on page 33. Check in advance whether the relevant food container can withstand and hold a vacuum.

To select the External Vacuum option, follow the steps below.

1. Select the External Vacuum program.
 - a. Press the **Pump Cleaning Program** button.
The display will show "C".
 - b. Press the **Cursor key**.
The display will show "E".

2. Program the External Vacuum program according to the steps specified in *10-Program Control System* on page 33.
3. Connect the external vacuum hose to the machine by placing the adapter over the suction inlet (1) in the vacuum chamber.
4. Connect the external vacuum hose to the packaging.
 - a. Connect the adapter (3) of the external vacuum hose to the valve of the packaging.
 - b. Slide the sliding valve (2) towards the hose (closed position).

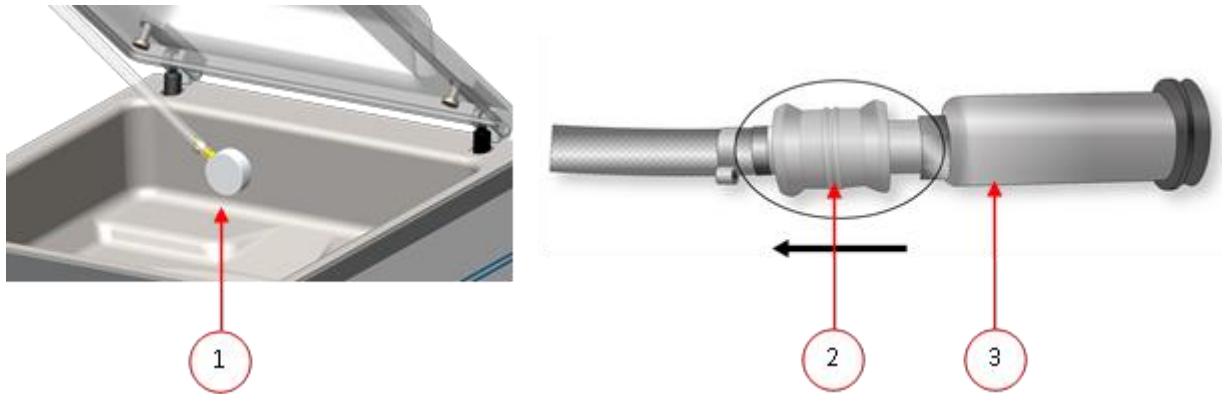

Figure 13: External Vacuum Adapter Set (10-Program Control System)

5. Press the **+ / VACUUM STOP** button to start vacuuming.
The packaging is vacuumed until the programmed value is reached.
6. Slide the sliding valve of the adapter towards the packaging (open position) and remove the external vacuum hose from the packaging.

6.7.1.12 Sleeper Option

If the Sleeper option is enabled, the pump will automatically shut off after the set time has elapsed and the machine is not in use during this period. The pump will automatically start again once a new vacuum cycle is started.

By default, the Sleeper option is set to 10 minutes. If you wish to change this time, please contact your supplier.



The Sleeper option cannot be set to less than 1 minute.

6.7.2 Advanced Control System (ACS)

Users can view the machine programs and activate the functions in the navigation mode. This is the mode that appears immediately after start-up.

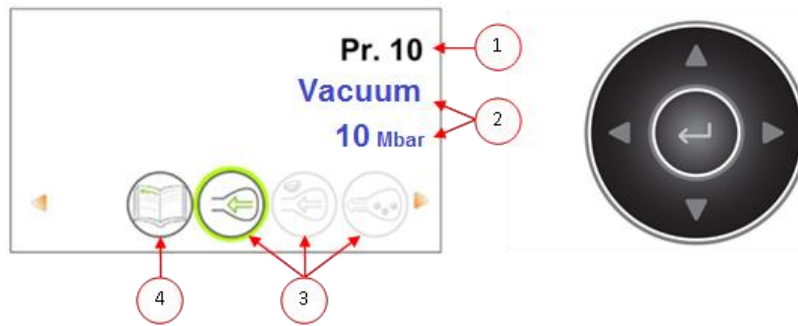

Figure 14: Screenshot of the navigation mode and the operating buttons of the ACS

No.	Element	Explanation
1.	Program number/name	The program shows the currently selected, pre-set program. By switching to a different program, other functions will be activated. The program selection depends on the product being packaged.
2.	Functions	These functions are active or inactive. If a function is active, it is displayed in a blue shade. If a function is inactive, it is displayed in a grey shade.
3.	Function active/inactive	The selected function is marked with a green circle. The name and current value of this function will appear on the screen. If the + functions are activated, the + is indicated in colour. If these functions are not active, they are displayed in a grey shade.
4.	Menu	The machine settings can be adjusted via the Menu pictogram at the left of the function overview.

1. Press the ▲ or ▼ buttons to select the desired program.
2. Press the ◀ or ▶ buttons to view the functions.
3. After selecting the desired function, press **Enter** to view and adjust the function settings.
Users can view the pre-set configuration and the owner is also authorised to change it.
4. Select the Machine Settings menu and press **Enter** to adjust the machine settings.
This menu can only be accessed by the owner. See *Guideline for Function Values* on page 46 for the possible limit values of the function values.

6.7.2.1 Programming the ACS Control Using the PC

You can import labels and programs from a USB stick by inserting the stick into the USB port of your machine. You can create the data to be imported using the online software that is available on the Support section of our website: <http://acs-configurator.com/>.

Follow the steps below to create a program or label:

1. Click on the link of the LX Software.
2. Click on **Select a program or label you want to change** to start a new program. You can also click on **Select a file to import** to import existing programs and/or labels from the machine.
3. Select the program or label you want to change and click the button **Go**.
4. Enter all the information you need.
5. Click on **Save** to save the program or label.

Each program and label should be stored separately using the **Save** button.

Once you finish all programs and labels, you can export them:

6. Click on **Export** to export programs or labels.
 - Click on **Programs** to save all programs.
 - Click on **Labels** to save all labels.

Use an empty USB stick to export the files to your machine.

To import the programs and labels into the machine, follow the steps below:

7. Insert a USB stick into the USB port of the machine.
8. In the menu, go to **Import/Export** and import the data.

6.7.2.2 Functions

The built-in functions of the machine can be enabled or disabled by the owner under Settings. See *Changing the ACS Settings* on page 27. The options of the various programs can then be programmed.

6.7.2.3 Vacuum

During the cycle, the air is removed from the chamber until the set pressure has been reached (sensor-controlled).

To set the Vacuum level, follow the steps below:

1. Press the cursor keys ◀ and ▶ and select the program Vacuum.
2. Press **Enter** to open the menu.
3. If Vacuum is not enabled, enable it. Press **Enter** and use the cursor keys ▲ and ▼ to turn ON Vacuum. Press **Enter**.
4. Use the cursor keys ▲ and ▼ to go to the value for the Vacuum and press **Enter**.
5. Set the desired value using the cursor keys ▲ and ▼ and press **Enter**.
6. Press the cursor key ◀ to return to the menu.
7. Close the lid to start the vacuum cycle.

6.7.2.4 Vacuum+ (optional)

If a lot of air is trapped in the product, it may be desirable to extend the vacuuming time after the maximum vacuum has been reached. This to allow entrapped air to escape from the product.

You can only set Vacuum+ if Vacuum has been set to the maximum (99.8%). To set the Vacuum+ option, follow the steps below:

1. Set the value of the Vacuum to the maximum (99.8%) as described in *Vacuum* on page 40.
2. Enable Vacuum+. Use the cursor keys ▲ and ▼ to go to the value for the Vacuum+ and press **Enter**.
3. Set the desired value using the cursor keys ▲ and ▼ and press **Enter**.
4. Press the cursor key ◀ to return to the menu.
5. Close the lid to start the vacuum cycle.

6.7.2.5 Gas (optional)

For the protection of the product, it may be desirable to insert a gas into the packaging after vacuuming. Optionally, the machine can be equipped with a gas flush system.

See *Technical Data* on page 63 for the connection details.



Never use a gas mixture containing more than 20% oxygen or other explosive gases. This may cause life-threatening explosions.



The insertion of gas lowers the seal pressure. The minimum final pressure (after the insertion of gas) must be 30% (300 mbar) to ensure proper sealing.

To set the Gas function, follow the steps below:

1. Press the cursor keys ▲ and ▼ and select the program Gas.
2. Press **Enter** to open the menu.
3. If Gas is not enabled, enable it. Press **Enter** and use the cursor keys ▲ and ▼ to turn ON Gas. Press **Enter**.
4. Use the cursor keys ▲ and ▼ to go to the value for Gas and press **Enter**.
5. Set the desired value using the cursor keys ▲ and ▼ and press **Enter**.
6. Press the cursor key ◀ to return to the menu.
7. Close the lid to start the vacuum cycle.

6.7.2.6 Gas+ (optional)

The Gas+ option only applies if the machine is equipped with the gas option. For some products it may be desirable to insert additional gas into the packaging to create a "balloon packaging". This allows for a better protection of a fragile product. The recommended value for Gas+ is 0.7 seconds.

To set the Gas+ option, follow the steps below:

1. Set the value of Gas in accordance with *Gas (optional)* on page 41.
2. Enable Gas+. Use the cursor keys ▲ and ▼ to go to the value for Gas+ and press **Enter**.
3. Set the desired value using the cursor keys ▲ and ▼ and press **Enter**.
4. Press the cursor key ◀ to return to the menu.
5. Close the lid to start the vacuum cycle.

6.7.2.7 Liquid Control (optional)

The Liquid Control option can be enabled or disabled for each program. If the product reaches the boiling point before the set vacuum is reached, the machine will proceed to the next step of the cycle.

To set the Liquid Control option, follow the steps below:

1. Press the cursor keys ◀ and ▶ and select the program Liquid Control.
2. Press **Enter** to open the menu.
3. If Liquid Control is not enabled, enable it. Press **Enter** and use the cursor keys ▲ and ▼ to turn ON Liquid Control. Press **Enter**.
4. Use the cursor keys ▲ and ▼ to go to the value for Liquid Control and press **Enter**.
5. Set the desired value using the cursor keys ▲ and ▼ and press **Enter**.
6. Press the cursor key ◀ to return to the menu.
7. Close the lid to start the vacuum cycle.

The Liquid Control function prevents excessive fluid from being drawn out of the product. This means that if the product reaches the boiling point, the machine will proceed to the next step of the cycle. Depending on the moisture content, the manner in which moisture is bound, the available surface for evaporation and the temperature, the end vacuum percentage might be limited and there might be too much residual oxygen content present in the package. If the product/process requires packaging with a low residual oxygen content, despite the high moisture content, there are two options:

1. Lower the product temperature. This allows for a deeper vacuum to be reached before the product reaches the boiling point.
2. Use the Liquid Control+ option.

6.7.2.8 Liquid Control+ (optional)

The Liquid Control+ time is set in seconds. This is the time the vacuuming will continue after detection of the evaporation point.

You can only set Liquid Control+ if Liquid Control has been set to the maximum (99.8%). To set the Liquid Control+ option, follow the steps below:

1. Set the value of Liquid Control to the maximum (99.8%) as described in *Liquid Control (optional)* on page 42.
2. Enable Liquid Control+. Use the cursor keys ▲ and ▼ to go to the value for Liquid Control+ and press **Enter**.
3. Set the desired value using the cursor keys ▲ and ▼ and press **Enter**.
4. Press the cursor key ◀ to return to the menu.
5. Close the lid to start vacuuming.

6.7.2.9 Red Meat (optional)

When packaging large pieces of fresh meat, the product continues to degas during the sealing phase. Since the opening of the vacuum bag is already closed, air pockets may form inside the package after decompressing. This function prevents these air pockets.

To set the Red Meat option, follow the steps below:

1. Press the cursor keys ◀ and ▶ and select the program Red Meat.
2. Press **Enter** to open the menu.
3. If Red Meat is not enabled, enable it. Press **Enter** and use cursor key ▲ and ▼ to turn ON Red Meat. Press **Enter**.
4. Use the cursor keys ▲ and ▼ to go to the value for the Ventilation Time and press **Enter**.
5. Set the desired value using the cursor keys ▲ and ▼ and press **Enter**.
6. Use the cursor keys ▲ and ▼ to go to the value for the Pause Time and press **Enter**.
7. Set the desired value using the cursor keys ▲ and ▼ and press **Enter**.
8. Press the cursor key ◀ to return to the menu.
9. Close the lid to start vacuuming.

A Red Meat+ function is also available. It works the same as the Vacuum+ function (see *Vacuum+ (optional)* on page 40).

6.7.2.10 Sequential Vacuum (optional)

The Sequential Vacuum option allows you to vacuum in up to 5 steps, alternating vacuuming steps with maintaining periods. Each step increases the vacuum reached in the previous step.

To set the Sequential Vacuum option, follow the steps below:

1. Press the cursor keys ◀ and ▶ and select the program Sequential Vacuum.
2. Press **Enter** to open the menu.
3. If Sequential Vacuum is not enabled, enable it. Press **Enter** and use the cursor keys ▲ and ▼ to turn ON Sequential Vacuum. Press **Enter**.
4. Use the cursor keys ▲ and ▼ to go to the value for the Vacuum 1 and press **Enter**.
5. Set the desired value using the cursor keys ▲ and ▼ and press **Enter**.
6. Use the cursor keys ▲ and ▼ to go to the value for the Time 1 and press **Enter**.
7. Set the desired value using the cursor keys ▲ and ▼ and press **Enter**.
8. Repeat steps 4 to 7 for the other Vacuum steps (2 to 5) and Times (2 to 5). At each Vacuum step, the value must be higher than that of the previous step.
9. Press the cursor key ◀ to return to the menu.
10. Close the lid to start vacuuming.

6.7.2.11 Marinating (optional)

This function is especially designed to accelerate the marinating of a product. This program allows definition of up to 5 vacuuming steps with intermediate ventilation steps.

The vacuuming steps have a fixed vacuum value of 80%, except for the last step. The last vacuuming step has an adjustable value of up to 99.8%. This also allows setting Vacuum+. The intermediate ventilation steps have a fixed value of 42%. After the last step, sealing takes place. To set the Marinating option, follow the steps below:

1. Press the cursor keys ◀ and ▶ and select the Marinating program.
2. Press **Enter** to open the menu.
3. If Marinating is not enabled, enable it. Press **Enter** and use the cursor key ▲ and ▼ to turn ON Marinating. Press **Enter**.

4. Use the cursor keys ▲ and ▼ to go to the value for the Vacuum of the last step and press **Enter**.
5. Use the cursor keys ▲ and ▼ to go to the number of steps and press **Enter**.
6. Use the cursor keys ▲ and ▼ to set the number of steps and press **Enter**.
7. Press the cursor key ◀ to return to the menu.
8. Close the lid to start vacuuming.

Vacuuming will take place in the set number of steps of 80% vacuum and 42% ventilation. Then vacuuming will continue until the set vacuum of the last step. If, for instance, 3 steps have been set with an end vacuum of 90%, vacuuming will take place as follows: 80% -> 42% -> 80% -> 42% -> 80% -> 42% -> 90%.

It is also possible to enable Liquid Control. This function will then only be active during the last vacuuming step. If, for instance, 3 vacuuming steps have been defined, Liquid Control will be active during the third step. Liquid Control+ is also possible here, see *Liquid Control+ (optional)* on page 42.

6.7.2.12 Tenderising (optional)

This feature has been designed to keep the chamber at a pre-determined vacuum level for a certain time. This is done to tenderise or degas the product.

To set the Tenderising option, follow the steps below:

1. Press the cursor keys ◀ and ▶ and select the program Tenderising.
2. Press **Enter** to open the menu.
3. If Tenderising is not enabled, enable it. Press **Enter** and use the cursor keys ▲ and ▼ to turn ON Tenderising. Press **Enter**.
4. Use the cursor keys ▲ and ▼ to go to the value for the Tenderising and press **Enter**.
5. Set the desired value using the cursor keys ▲ and ▼ and press **Enter**.
6. Use the cursor keys ▲ and ▼ to go to the value for the Tenderising Time and press **Enter**.
7. Set the desired value using the cursor keys ▲ and ▼ and press **Enter**.
8. Use the cursor keys ▲ and ▼ to go to the value for Accuracy and press **Enter**.
9. Set the desired value using the cursor keys ▲ and ▼ and press **Enter**.
10. Press the cursor key ◀ to return to the menu.
11. Close the lid to start vacuuming.

6.7.2.13 Seal

This is the time that the sealing wire and/or the cut-off wire are heated. The longer the time, the more heat is transferred to the bag.

As an option, the machine can be equipped with a Seal 1-2 option. This means the seal wire is activated separately from the cut-off wire. This way the cut-off wire can be activated a bit longer, to cut through thicker bags.

To set the Seal option, follow the steps below:

1. Press the cursor keys ◀ and ▶ and select the program Seal.
2. Press **Enter** to open the menu.

3. Use the cursor keys ▲ and ▼ to go to the value for the Sealing Time and press **Enter**.
4. Set the desired value using the cursor keys ▲ and ▼ and press **Enter**.



When Seal 1-2 is activated, the cut-off time cannot be set lower than the seal time.

5. Press the cursor key ◀ to return to the menu.
6. Close the lid to start sealing.

6.7.2.14 Soft-Air (optional for the Falcon)

This is the time that air is softly released into the chamber after sealing has taken place.

To set the Soft-air function, follow the steps below:

1. Press the cursor keys ▲ and ▼ and select the program Soft-air.
2. Press **Enter** to open the menu.
3. If Soft-air is not enabled, enable it. Press **Enter** and use the cursor keys ▲ and ▼ to turn Soft-air ON. Press **Enter**.
4. Use the cursor keys ▲ and ▼ to go to the value for the Soft-air time and press **Enter**.
5. Set the desired value using the cursor keys ▲ and ▼ and press **Enter**.
6. Press the cursor key ◀ to return to the menu.
7. Close the lid to start sealing.

6.7.2.15 External Vacuum (optional)

The External Vacuum function allows special food containers to be vacuumed outside the machine. The packaging is vacuumed until a vacuum of 99.8% is reached.

External Vacuum is only available on the Cyclone series.

Check in advance whether the relevant food container can withstand and hold a vacuum.

To select the External Vacuum option, follow the steps below:

1. Connect the external vacuum hose to the machine by placing the adapter over the suction inlet (1) in the vacuum chamber.
2. Connect the external vacuum hose to the packaging.
 - a. Connect the adapter (3) of the external vacuum hose to the valve of the packaging.
 - b. Slide the sliding valve (2) towards the hose (closed position).

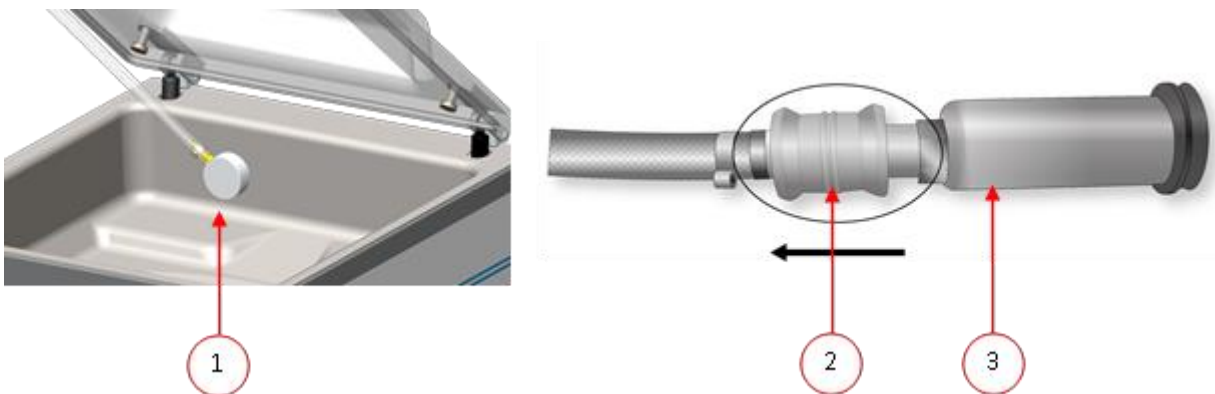

Figure 15: External Vacuum Adapter Set (ACS)

3. Press the cursor keys and select the program External Vacuum to start vacuuming. The packaging is vacuumed until the maximum vacuum is reached.
4. Slide the sliding valve of the adapter towards the packaging (open position) and remove the external vacuum hose from the packaging.

6.7.2.16 Sleeper Option

If the Sleeper option is enabled, the pump will automatically shut off after the set time has elapsed and the machine is not in use during this period. The pump will automatically start again once a new vacuum cycle is started.

By default, the Sleeper option is set to 10 minutes. If you wish to change this time, please contact your supplier.



The Sleeper option cannot be set to less than 1 minute.

6.7.2.17 Dealer Information

If dealer information is entered into the machine, this will be displayed on the start-up screen.

6.8 Guideline for Function Values

For each function, values can be set if you are authorised as an owner. In order to understand the consequence of the set value, the table below explains the consequences of giving a low or high value for each function.

For the values in the table below, the following rule of thumb applies to setting a value in mbar. These values may vary slightly, depending on the humidity.

- 99.8% = 2 mbar
- 0% = 1013 mbar

Function	Range	Conditions
Vacuum	0 – 99% (for 10-prog control) 30 – 99.8% (for ACS)	Rule of thumb: the higher the vacuum, the less oxygen remains in the package and the longer the shelf life of the product. There are exceptions to this rule.
Vacuum+	0 – 99 seconds (for 10-prog control) 0 – 20 seconds (for ACS)	This is the time the vacuuming will continue after the maximum vacuum has been reached. This to allow entrapped air to escape from the product. Please note that the vacuum must be set to the maximum.
Gas	30 – 98% (for 10-prog control) 1 – 69% (for ACS)	For some products it may be desirable to insert gas into the packaging to increase the shelf life of the product.

Function	Range	Conditions
Gas+	0.1 – 1 second	For some products it may be desirable to insert additional gas into the packaging to create a "balloon packaging". This allows for a better protection of a fragile product. The recommended value for Gas+ is 0.7 seconds.
Red meat	0.1 – 1 second	When packaging large pieces of fresh meat, the product continues to degas during the sealing phase. Since the opening of the vacuum bag is already closed, air pockets may form inside the package after decompressing. This function prevents these air pockets.
Liquid Control	0 – 99% (for 10-prog control) 30 – 99.8% (for ACS)	If the pressure is reduced, the boiling point of liquids will be decreased. As a result of this law of nature, a product may start boiling. In addition to contamination of the machine, this will reduce the weight and quality of the product to be packaged. By enabling the Liquid Control function, this special sensor will detect the evaporation point, and the program will stop vacuuming and proceed to the next step in the packaging process. The value that can be set is the maximum achievable vacuum value. Please keep in mind that this maximum vacuum value can only be achieved as long as the product does not start boiling.
Liquid Control+	1 – 99 seconds (for 10-prog control) 0.1 – 5.0 seconds (for ACS)	This is the time the vacuuming will continue after detection of the evaporation point. Because of the evaporation, a minor shockwave may occur, pushing all remaining air from the bag. The best way to determine the right time is trial and error.
Sequential Vacuum (ACS)/Multi-Cycle Vacuum (10-prog control)	0 – 99% (for 10-prog control) 30 – 99.8% (for ACS)	If the value for the Vacuum+ time is insufficiently effective for the entrapped air to escape, the Sequential Vacuum/Multi-Cycle Vacuum Step must be enabled. In maximum five steps, vacuuming is alternated with maintaining time. Each step increases the vacuum reached in the previous step.
Marinating	42 – 99.8% Steps: 1 – 5	Only in case of ACS control. This is the adjustable value of the last step. If it is set to 40%, no more vacuuming will take place during this step, but it will immediately proceed to sealing. 1 – 5 steps can be set. The set end vacuum can only be achieved during the last step.

Function	Range	Conditions
Tenderising	30 – 99.8% Time: 0 – 30 minutes	Only in case of ACS control. This is the value at which the tenderising takes place. The duration of the tenderising process can also be set.
Seal time 1-2 cutting time	0.1 – 4.0 seconds	This is the time that the sealing wire and/or the cut-off wire are heated. The longer the time, the more heat is transferred to the bag.
Soft-air	0 – 99 seconds (for 10-prog control) 0 – 20 seconds (for ACS)	This is the time that air is softly released into the chamber after sealing has taken place. The best way to determine the right time is trial and error.
Cleaning of the pump	15 minutes	Fixed value.
Sleeper option	1 – 100 minutes (for 10-prog control) 1 – 59 minutes (for ACS)	This is the time the pump will continue running after running a cycle. This maintains the pump at operating temperature and prevents unnecessary starting and stopping of the pump, which causes additional wear of the pump.



The vacuum in the chamber must be at least 30% at the moment of sealing.

If the pressure is reduced, the boiling point of liquids will be decreased; see *Figure 16: Vapour Pressure Curve of Water* on page 49. As a result of this law of nature, a product may start boiling. In addition to contamination of the machine, this will reduce the weight and quality of the product to be packaged.

When packaging moisture-containing products, such as soups and sauces, it is important to closely monitor the vacuuming process. The moment bubbles are formed or the product starts to bubble, you should immediately proceed to the next step in the cycle. See *Proceeding to the Next Step in the Cycle* on page 32.

By letting products cool down sufficiently prior to starting the vacuuming process, a higher vacuum can be achieved.

If the machine is equipped with the Liquid Control option, the control will automatically proceed to the next step if the product starts boiling.

When packaging moisture-containing products, it is important to run the pump cleaning program at least once a week. When moisture-containing products are vacuumed on a daily basis, it is recommended to run the pump cleaning program at the end of the day.

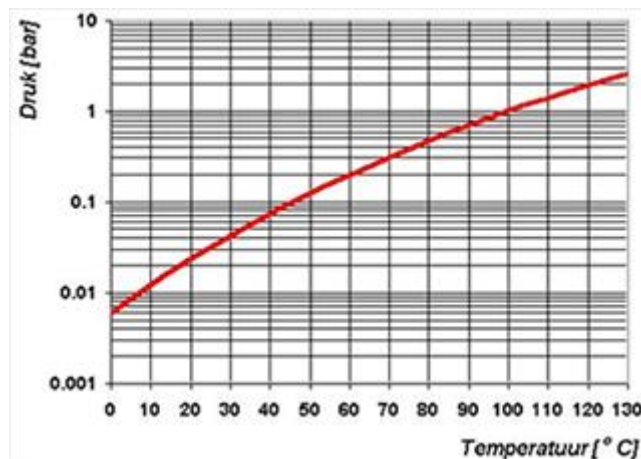

Figure 16: Vapour Pressure Curve of Water

6.9 Printer (ACS only)

A printer can be connected to the machine to print package labels.



From software version 90, the mounted sensor is automatically detected. A message is displayed if you close the lid and no sensor is detected.

6.9.1 Connecting a Printer

To connect a printer to the machine, follow the steps below:

1. Connect the printer to the mains supply.
2. Connect the printer to the USB connector on the machine.
3. Turn on the printer.
4. Select the correct printer in the machine menu.
 - a. Open the menu.
 - b. Enter the owner code 1324.
 - c. Go to **Settings**.
 - d. Go to **1.1 Printer**.
 - e. Select **ZD410**.
 - f. Press the cursor key ◀ to return to the menu.

6.9.2 Creating a Label

To create a label, perform the steps below:

1. Open the menu.
2. Enter the owner code 1324.
3. Go to **Settings**.
4. Go to **1.1 Printer**.
5. Go to **Labels**.
6. Enter the desired information.

1. Customer name
2. Label number
3. Name
4. Info
5. Use by / Storage life
6. Storage temperature
7. Print customer name Y/N
8. Print info Y/N
9. Print achieved vacuum Y/N
10. Print expiry date Y/N
11. Print user Y/N
12. Print storage temperature Y/N

Once the printer is selected and the required information for the label is entered, the printer can be activated on each separate program. To do this, go to the main menu, all the way to the right. Here you can enable or disable the printer and select the label number you require. You can also select the number of labels you require per cycle.

If you require an additional label after the complete cycle has ended and all labels have already been printed, select the **Print extra label** option. This will print the last printed label again.

To replace the label roll, follow the instructions in *Replacing a Printer Roll* on page 75.

To align the printer prior to printing the first label, follow the instructions in *Aligning the Printer* on page 76.

7 Maintenance

When carrying out maintenance work, always observe the following safety rules.

- Only trained technicians are authorised to perform the described maintenance activities.
- Always disconnect the power supply by turning the main switch to "0" or disconnecting the plug.
- Always disconnect the air supply (if applicable).
- Test the machine after carrying out maintenance work or repairs to make sure the machine can be used safely.

7.1 Maintenance Schedule

The diagram below shows the maintenance activities that must be performed and the interval with which these activities must be performed.

For specific descriptions for performing maintenance activities, consult the appropriate section within *Maintenance* on page 51.

Activity *	1-D	1-W	6-M	1-Y	4-Y
Cleaning					
Cleaning the machine.	X				
Inspections					
Check the oil level.		X			
Run the pump cleaning program.		X			
Inspect the sealing bars.		X			
Inspect the silicone rubber of the silicone holders.		X			
Inspect the lid gasket.		X			
Check the plastic lid for cracks (if applicable).		X			
Inspect the lid springs. Pay additional attention to damage and the fastenings of the lid springs.		X			
Lubrication					
Lubricate the grease nipples of the parallel arms at the pivot point using FDA approved bearing grease.			X		
Replace the oil and the oil filter of the vacuum pump. See <i>Technical Data</i> on page 63 for the type of oil.			X		
Replacement					
Replace the sealing wires.			X		
Replace the silicone rubber of the silicone holders.			X		
Replace the lid gasket.			X		

Activity *	1-D	1-W	6-M	1-Y	4-Y
Replace the oil exhaust filter.				X	
Replace the oil filter.				X	
Contact your dealer for professional servicing.				X	
Replace the plastic lid (if applicable).					X

* 1-D = Daily, 1-W = Weekly, 6-M = Every 6 months, 1-Y = Annually, 4-Y = Every 4 years

7.2 Cleaning the Machine



Never clean the machine using a high pressure cleaner.

Do not use any aggressive or toxic cleaning agents.

Do not use any cleaning agents containing solvents.

1. Clean the surfaces with a soft, damp cloth. You can also apply a cleaning agent to the machine and wash it with clean water.

7.3 Running the Pump Cleaning Program

The pump cleaning program runs the vacuum pump for 15 minutes. During the program, the pump and the oil reach the operating temperature. Moisture in the pump is absorbed by the oil. The high temperature causes any moisture in the pump to evaporate, and minimises the risk of corrosion.

It is advisable to run the program before using the machine for the first time, after the machine has been stationary for a lengthy period of time, and especially prior to changing oil.

Run the pump cleaning program every week. If you package moisture-containing products, such as soups and sauces, the pump cleaning program should be run every day.

1. Select the pump cleaning program.

10-program control system Press the **Pump Cleaning Program** button.

ACS Press the ▲ button or the ▼ button to browse to the pump cleaning program.

2. Close the lid to start the pump cleaning program.
The pump cleaning program will run for 15 minutes.

7.4 Removing Oil, Replacing Oil Filter, Refilling Oil

This section describes how to remove oil from the pump, replace the oil filter and refill the oil.

See *Vacuum Pump* on page 20 for an overview of the pump parts.

If the machine remains unused for a prolonged period of time, the oil must be removed from the pump. This is necessary because moisture and dirt in the oil may affect the pump, causing the pump to jam at the next use.



The oil in the vacuum pump may be hot. Avoid contact with hot oil when removing the oil.

Follow the steps below to remove the oil from the pump:

1. Place a drip pan under the oil drain plug.
2. Remove the oil drain plug.
The oil will drain from the pump.
3. Replace the oil drain plug.

Follow the steps below to replace the oil filter:

4. Remove the old oil filter.
5. Insert a new oil filter.

Follow the steps below to add oil to the pump. You can follow these steps after all oil has been removed, but also to refill oil.

6. Remove the oil drain plug.
7. Add oil until the oil level is between the minimum and maximum levels.
8. Replace the oil drain plug.

7.5 Replacing the Oil Exhaust Filter

The oil exhaust filter prevents oil vapours from being emitted from the vacuum pump with the exhaust air. If the filter becomes saturated, the maximum vacuum level can no longer be reached. Replace the filter in case of vacuuming problems or as specified in *Maintenance Schedule* on page 51.

7.5.1 Pump 76 m³ / 2684 cf/h

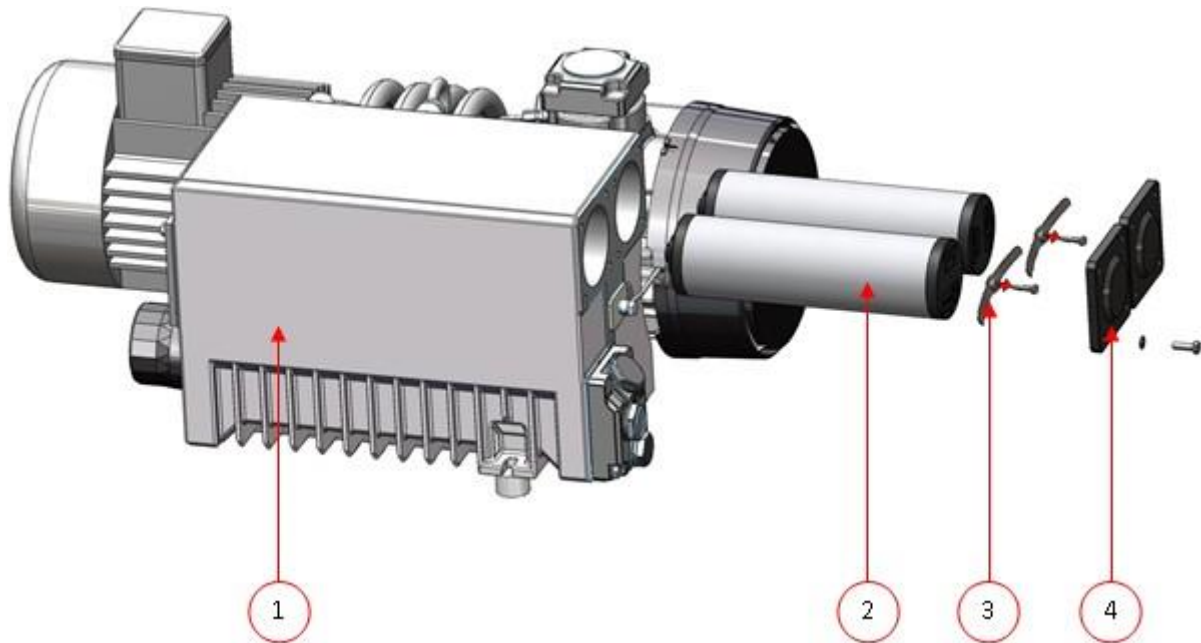

Figure 17: Replacing the Oil Exhaust Filter (Pump 76 m³/2684 cf/h)

Follow the steps below to remove the old oil exhaust filter:

1. Remove the filter cover (4) of the vacuum pump (1) and put it aside.
2. Remove the leaf spring (3) and put it aside.
3. Remove the old filter (2).

Follow the steps below to install a new oil exhaust filter:

4. Insert the new filter into the vacuum pump.

Make sure the O-ring is properly placed on the filter inlet.

5. Mount the leaf spring placed aside.
6. Mount the filter cover placed aside.

7.6 Replacing the Sealing Wire

Depending on the specifications of your machine, you can have one of the following (combinations of) sealing wires:

- Wide seal: one wide sealing wire
- Cut-off seal: one sealing wire and one cutting wire
- Double seal: two sealing wires
- Bi-active seal: one seal bar with a wide sealing wire on both sides

The process of replacing the sealing wires is the same for all types.



Make sure, for bi-active seal systems, that the upper and lower sealing wires are aligned precisely during the sealing.

Replace the sealing wires if the wire and/or the Teflon tape are damaged, or as specified in *Maintenance Schedule* on page 51.

On machines with a plastic lid, the sealing bars are mounted on cylinders (Figure 18: *Removing the Sealing Bar (Plastic Lid)* on page 55). On machines with a metal lid, the sealing bars are mounted in the lid (Figure 19: *Removing the Sealing Bar (Metal Lid)* on page 55).



Figure 18: *Removing the Sealing Bar (Plastic Lid)*

1. Remove the sealing bar.

Plastic lid Lift the sealing bar from the cylinders. See *Figure 18: Removing the Sealing Bar (Plastic Lid)* on page 55.

Metal lid See *Figure 19: Removing the Sealing Bar (Metal Lid)* on page 55. Remove the sealing bar from the holders (4) by disconnecting the two electrical connector plugs (2) and removing the M6 screw (3).

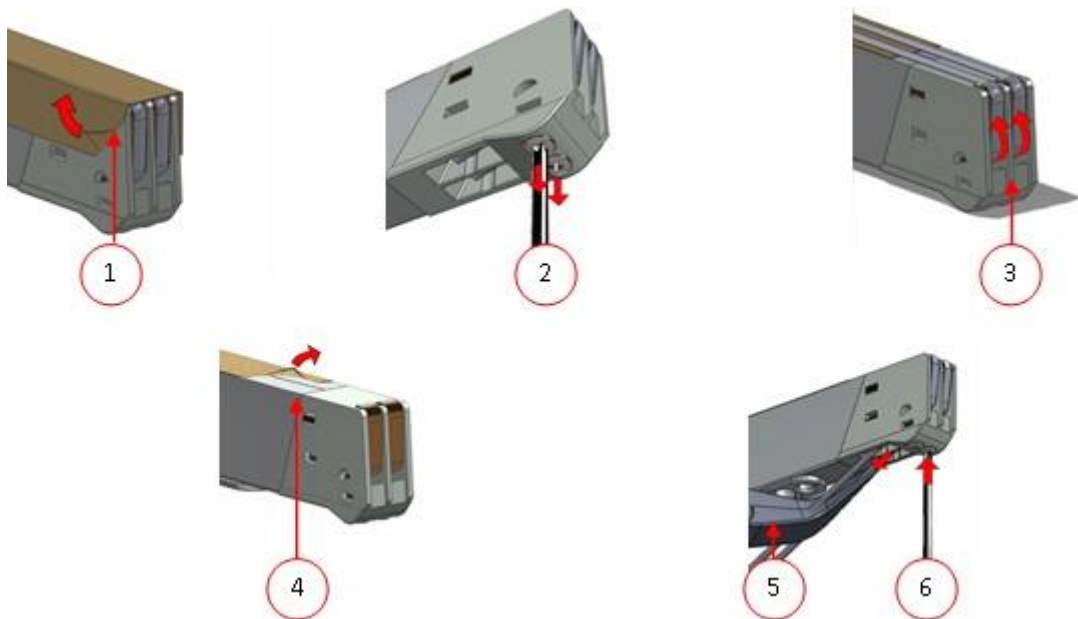

Figure 20: *Replacing the Sealing Wire*

2. Remove the Teflon tape (1) that protects the sealing wire.
3. Remove the screws (2) at the bottom of the sealing bar and remove the sealing wires (3).4. Replace the Teflon tape on the sealing bar.
 - a. Pull the Teflon tape from the top of the sealing bar (4).
 - b. Clean the sealing bar with a dust-free cloth.
 - c. Apply a new piece of Teflon tape of the same length on the sealing bar.
5. Replace the sealing wires.
 - a. Cut a new piece of sealing wire or cutting wire at the length of the sealing bar plus approximately 15 cm.
 - b. First place the wire on one side of the sealing bar by tightening the screws (2).
 - c. Place the other end of the wire in its location and tension it with pliers. Now fasten it by tightening the screws.
 - d. Cut both ends of the wire.
6. Replace the Teflon tape on the sealing wire.
 - a. Cut a piece of Teflon tape at the length of the sealing bar plus approximately 5 cm.
 - b. Attach the tape over the sealing wires on the sealing bar evenly and without folds.
 - c. Cut the tape.
7. Place the sealing bar back in its position.

7.7 Replacing the Silicone Rubber of the Silicone Holders

To ensure a seal of good quality, the silicone rubber may not be damaged and the surface must be smooth. Mechanical contact or burning by the sealing wire may damage the rubber.

Replace the silicone rubber if damaged or as specified in *Maintenance Schedule* on page 51.

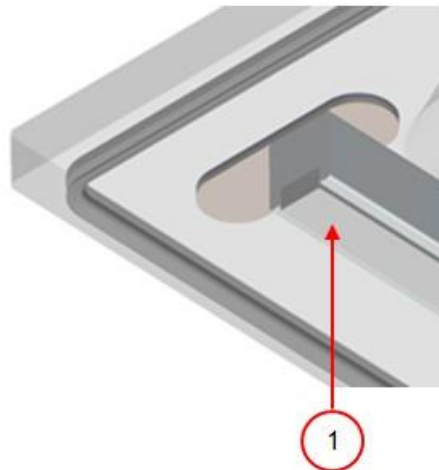

Figure 21: Replacing the Silicone Rubber of the Silicone Holders

1. Pull the old silicone rubber from the holder, see *Figure 21: Replacing the Silicone Rubber of the Silicone Holders* on page 56.
2. Cut a new piece of silicone rubber. Make sure it is the same length as the holder.



If the rubber is too short or too long, this may cause problems with the seal of the bag.

3. Install the new piece of silicone rubber by pressing it into the recess of the silicone holder. Ensure that the silicone rubber is fully and uniformly placed in the recess. It is also important that the surface of the silicone rubber is smooth after it is in place, and that it shows no signs of stress.

7.8 Replacing the Lid Gasket

The lid gasket ensures the vacuum chamber is fully closed during the machine cycle. This is essential to reach the maximum vacuum level. Due to extreme pressure differences, the gasket wears and should therefore be replaced regularly.

Replace the lid gasket if damaged or as specified in *Maintenance Schedule* on page 51.



Figure 22: Replacing the Lid Gasket

1. Pull the old gasket loose to remove it.
2. Cut a new piece of rubber.



Preferably cut the new piece of rubber slightly longer than the old piece.
The edges must be cut straight.



If the lid gasket is too short or too long, this may cause problems when closing the lid or it may cause leakage.

3. Install the new gasket by pressing it into the gasket slot. The lip of the gasket must face downwards and outwards.
The gasket should be placed in the slot evenly and without any tension. The edges must be placed closely together to prevent leakage.

7.9 Inspecting the Lid Springs

1. Check the fastenings of the lid springs for wear, corrosion and damage.
2. Check the lid springs for wear and damage.



In the case of irregularities, please contact your service dealer.

8 Troubleshooting

The tables below show the possible malfunctions and the corresponding causes as well as the steps to be taken.

Malfunction	Activity	More information
Control panel does not illuminate.	<ul style="list-style-type: none"> • Connect the machine to the power supply. • Check the machine/circuit breaker. 	<i>Electrical Installation</i> on page 20.
The control panel is on, but there is no activity after closing the lid.	<ul style="list-style-type: none"> • Check or adjust the switch of the lid. 	Contact your supplier.
Insufficient end vacuum.	<ul style="list-style-type: none"> • Check the vacuum settings of the program and adjust them. • Make sure that the extraction opening is not covered. • Check the oil level in the pump. • Check/replace the oil exhaust filter. • Check/replace the lid gasket. 	<i>Changing the Program Settings</i> on page 33. <i>Vacuum Pump</i> on page 20. <i>Replacing the Oil Exhaust Filter</i> on page 53. <i>Replacing the Lid Gasket</i> on page 57.
Vacuum process is slow.	<ul style="list-style-type: none"> • Make sure that the extraction opening is not covered. • Check the oil level in the pump. • Check/replace the oil exhaust filter. 	<i>Vacuum Pump</i> on page 20. <i>Replacing the Oil Exhaust Filter</i> on page 53.
Vacuum bag is not sealed correctly.	<ul style="list-style-type: none"> • Check the seal settings of the program and adjust them. • Check/replace the Teflon tape and the sealing wires. • Check/replace the silicone rubber of the silicone holders. 	<i>Changing the Program Settings</i> on page 33. <i>Replacing the Sealing Wire</i> on page 54. <i>Replacing the Silicone Rubber of the Silicone Holders</i> on page 56.

Malfunction	Activity	More information
	<ul style="list-style-type: none"> Check the inside of the vacuum for contamination and clean it. 	
The lid does not open automatically.	<ul style="list-style-type: none"> Check the gas spring/springs of the lid. 	Contact your supplier.

Error messages for the 10-program control system

Malfunction	Activity	More information
F1 in display.	<ul style="list-style-type: none"> Check or adjust the switch of the lid. Verify that the vacuum pump is running. 	Contact your supplier.
F2 in display of the 10-program control system with sensor control.	<ul style="list-style-type: none"> Check whether the lid is open and restart the machine. If the message appears again, please contact your supplier. 	Contact your supplier.
--- in display.	<ul style="list-style-type: none"> Check whether the lid is open. 	
Flashing "C" in display.	<ul style="list-style-type: none"> This is a reminder to run the Pump cleaning program. 	Run the pump cleaning program

Error messages for the Advanced Control System

Malfunction	Activity	More information
Message "Sensor missing" in display.	<ul style="list-style-type: none"> Check whether the sensor is connected. 	
Message "Cycle aborted" in display.	<ul style="list-style-type: none"> Check whether the lid is open. 	

9 Terms of Warranty

The warranty is subject to the following limitations. The warranty period for products supplied by Eurodib is 1 year from the date indicated on the purchase document. This warranty is limited to manufacturing and machining defects and therefore does not cover breakdowns involving any part of the product that is exposed to any form of wear and tear. Normal wear and tear that may be expected with the use of this product is therefore hereby excluded.

- The responsibility of Eurodib is limited to replacing defective parts; we shall not acknowledge claims for any other kind of damage or costs.
- The warranty automatically expires in case of overdue or poor maintenance.
- If there are doubts about the maintenance activities or if the machine fails to work correctly, always contact the supplier.
- The warranty does not apply if the defect is the result of incorrect or negligent use, or maintenance that was conducted contrary to the instructions given in this manual.
- The warranty is void in the event of repairs or modifications to the product by third parties.
- Defects due to damage or accidents caused by external factors are excluded from the warranty.
- If we replace parts in compliance with the obligations of this warranty, then the replaced parts become our property.

The provisions regarding the warranty and liability are part of the general terms and conditions of sale, which can be sent to you upon request.

9.1 Liability

- We exclude all liability insofar as far as it is not required by law.
- Our liability shall never exceed the total amount of the machine value in question.
- With the exception of the applicable legal regulations of public order and good faith, we are not liable to pay for any damage of any sort whatsoever to the counterparty or to third parties, directly or indirectly, including lost profits, damage to movable or immovable property or personal injury.
- We are in no way liable for damages arising from or resulting from the use of the product used, or the unsuitability thereof for the purpose for which the other party decided to purchase the product.

10 Disposal



Do not dispose of oil and components as household waste. When replacing oil or components at the end of the service life, ensure that all materials are collected and disposed or reused in a legal and environmentally sound manner.

11 Appendices

11.1 Technical Data

11.1.1 Technical Data Cyclone

Cyclone	201 D	203 D
General		
Ambient temperature during operation	41 to 86°F	41 to 86°F
Sound emission	< 70 dB(A)	< 70 dB(A)
Maximum daily production	8 hrs/day	8 hrs/day
Dimensions of the machine		
Width	27.4 in	27.4 in
Length	28.0 in	28.0 in
Height	40.4 in	40.4 in
Weight	364 lbs	364 lbs
Maximum product height	7.9 in	7.9 in
Gas flush system (optional)		
Dimensions connector	0.24 in	0.24 in
Gas supply	60-100 l/min	60-100 l/min
Maximum supply pressure	1 bar	1 bar
Electrical connection		
Supply voltage	*	*
Connected load	*	*
Vacuum pump		
Capacity	75 m ³ /h / 2684 cf/h	75 m ³ /h / 2684 cf/h
Oil	1 litre	1 litre
Type of mineral oil	VS 100	VS 100
Ambient temperature mineral oil	14 to 104°F	14 to 104°F

*See machine plate.

11.2 Example Programs

Example programs of the 10-program control system

Prog	Vacuum	Vacuum+	Seal	Soft-air	Type of product
1.	99%	OFF	2.2 s	3 s	Solid products
2.	97%	N/A	2.2 s	OFF	Liquids/liquid-containing products
3.	99%	OFF	2.2 s	8 s	Fragile/sharp products
4.	99%	4 s	2.2 s	3 s	Product that may contain entrapped air

Set as sensor-controlled

Prog no.	1	2	3	4	5	6	7	8	9	10
Vacuum	99%	97%	99%	99%	80%	90%	50%	90%	60%	99%
Vacuum+	OFF		OFF	4 s						15
Gas	OFF	OFF	OFF	60%	50%	80%	OFF	80%	30%	OFF
Seal	2.2 s	2.2 s	2.2 s	2.2 s	2.5 s	2.5 s	2.5 s	2.5 s	2.5 s	2.5 s
Seal 2	3.5 s	3.5 s	3.5 s	3.5 s	3.5 s	3.5 s	3.5 s	3.5 s	3.5 s	3.5 s
Soft-air	3 s	OFF	8 s	3 s	OFF	OFF	2 s	OFF	OFF	3 s

Set as controlled by Liquid Control sensor

Prog no.	1	2	3	4	5	6	7	8	9	10
Vacuum	99%	97%	99%	99%	H2O	90%	50%	90%	60%	99%
Vacuum+	OFF		OFF	4 s						15
Gas	OFF	OFF	OFF	60%	50%	80%	OFF	80%	30%	OFF
Seal	2.2 s	2.2 s	2.2 s	2.2 s	2.5 s	2.5 s	2.5 s	2.5 s	2.5 s	2.5 s
Seal 2	3.5 s	3.5 s	3.5 s	3.5 s	3.5 s	3.5 s	3.5 s	3.5 s	3.5 s	3.5 s
Soft-air	3 s	OFF	8 s	3 s	OFF	OFF	2 s	OFF	OFF	3 s

Set as time-controlled										
Prog no.	1	2	3	4	5	6	7	8	9	10
Vacuum	25 s	20 s	15 s	10 s	30 s	25 s	20 s	20 s	15 s	30 s
Gas	OFF	OFF	OFF	OFF	5 s	5 s	10 s	15 s	15 s	OFF
Seal	2.2 s	2.2 s	2.2 s	2.2 s	2.5 s	2.5 s	2.5 s	2.5 s	2.5 s	2.5 s
Seal 2	3.5 s	3.5 s	3.5 s	3.5 s	3.5 s	3.5 s	3.5 s	3.5 s	3.5 s	3.5 s
Soft-air	3 s	OFF	8 s	3 s	OFF	OFF	2 s	OFF	OFF	3 s

Example programs of the ACS control system

Prog	Vacuum	Vacuum+	Seal	Soft-air	Type of product
1.	99.8%	OFF	2.2 s	3 s	Solid products
2.	97%	N/A	2.2 s	OFF	Liquids/liquid-containing products
3.	99.8%	OFF	2.2 s	8 s	Fragile/sharp products
4.	99.8%	4 s	2.2 s	3 s	Product that may contain entrapped air

Set as sensor-controlled or controlled by Liquid Control sensor										
Prog no.	1	2	3	4	5	6	7	8	9	10
Vacuum	99.8%	97%	99.8%	99.8%	99.5%	99.5%	99.5%	90%	95%	90%
Vacuum+	OFF		OFF	4 s						15
Gas	OFF	OFF	OFF	OFF	OFF	60%	OFF	OFF	OFF	OFF
Seal	2.2 s	2.2 s	2.2 s	2.2 s	2.5 s	2.5 s	3.5 s	3.5 s	2.5 s	2.5 s
Seal 2	2.2 s	2.2 s	2.2 s	2.2 s	2.5 s	2.5 s	4.0 s	3.5 s	2.5 s	2.5 s
Soft-air	3 s	OFF	8 s	3 s	5 s	OFF	OFF	5 s	5 s	5 s

Set as sensor-controlled or controlled by Liquid Control sensor										
Prog no.	11	12	13	14	15	16	17	18	19	20
Vacuum	99.8%	99.8%	99.8%	99.8%	99.5%	99.8%	90%	95%	95%	99.8%
Vacuum+	OFF	OFF	5 s	5 s		5 s				OFF
Gas	50%	40%	OFF	70%	70%	OFF	68%	OFF	OFF	OFF
Seal	2.5 s	2.5 s	2.0 s	2.0 s	2.0 s	2.0 s	2.0 s	2.0 s	2.0 s	2.0 s
Seal 2	2.5 s	2.5 s	2.0 s	2.0 s	2.0 s	4.0 s	2.0 s	2.0 s	2.0 s	4.0 s
Soft-air	OFF	OFF	OFF	5 s	OFF	OFF	OFF	OFF	OFF	OFF

11.4 Replacing a Printer Roll

Follow the steps below to place the label roll in the printer.



Despite the inner diameter of the label roll being bigger than the holder, the roll can be used without any issues.

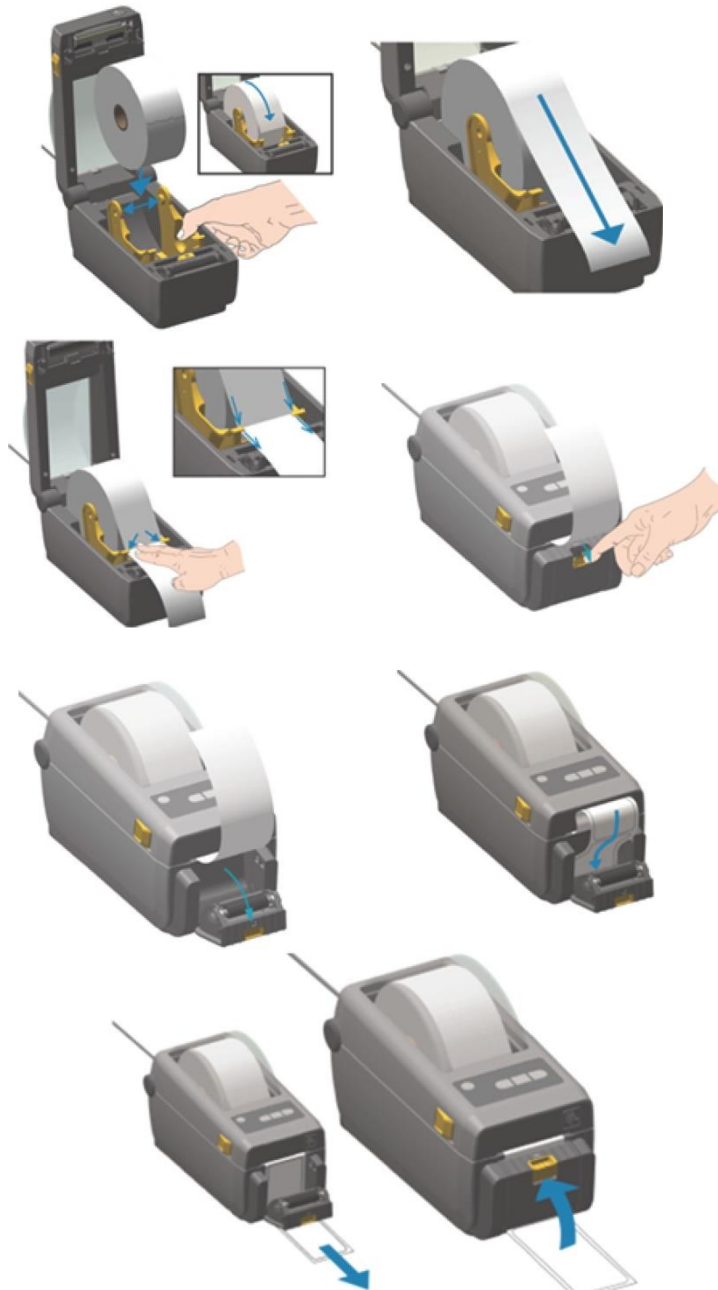

Figure 23: Replacing the Printer Roll

11.5 Aligning the Printer

1. Switch on the printer and make sure the indication light is green.
2. Press the **Pause** and **Cancel** button simultaneously for 2 seconds.

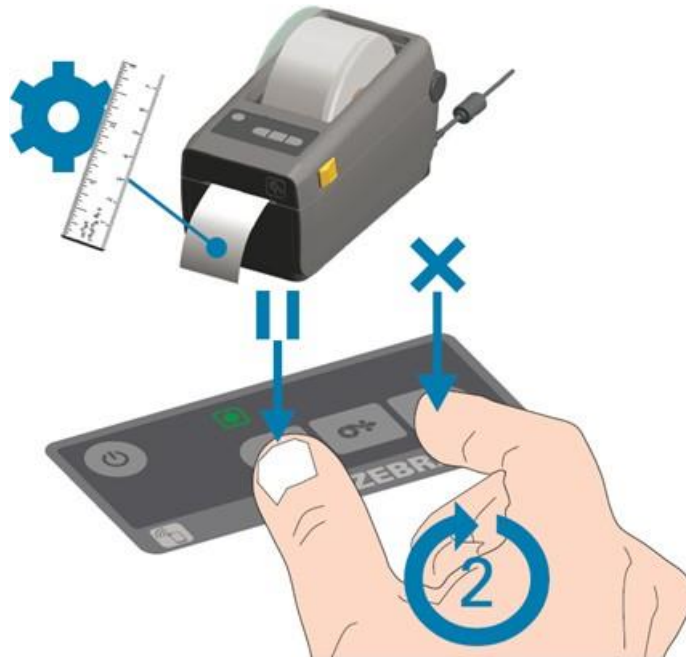

Figure 24: Aligning the Printer

The printer will print several labels and determine the correct position.

3. Press the **Feed** and **Cancel** button simultaneously for 2 seconds.

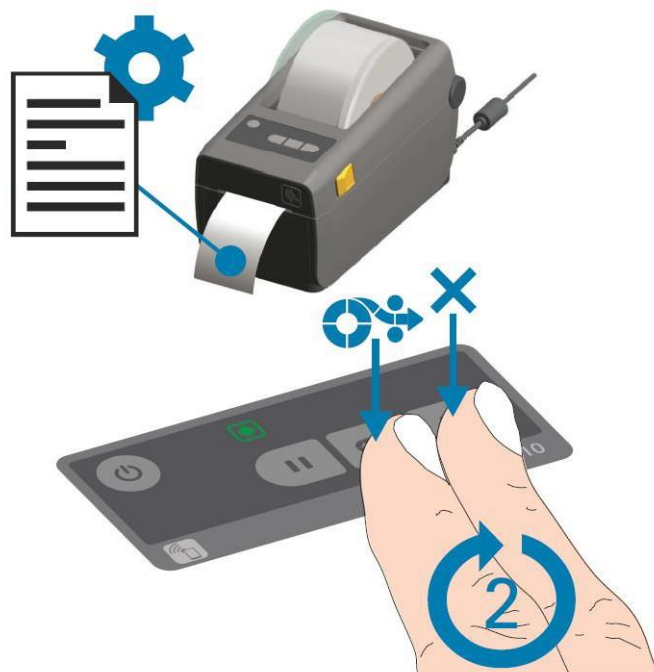

Figure 25: Printing the First Label

The printer will print the first label.

4. Remove the first printed label to print the next labels.



EURODIB
120, rue de la Barre
BOUCHERVILLE
QC J4B 2X7
CANADA

Tel. 1 888 956 6866
www.eurodib.com /
info@eurodib.com

EURODIB Inc.
156 Lawrence Paquette
Champlain
NY 12919
USA

Tel. 1 888 956 6866