

# ATMOVAC™

## VACUUM MACHINES



Made in the Netherlands



# KAZE

KAZE perfectly balances ease-of-use, sturdy construction and advanced technology. Simple control panel with graphic display. Seamless welding design. Precise vacuum settings with sensor pressure control. Comprehensive maintenance menu. Service Alarm.

Liquid control\* INCLUDED with all KAZE machines, in addition to:

- 3-program memory
- Sensor control\*\*
- Soft air
- Double seal
- Red meat packaging
- Pump cleaning cycle

Optional add-ons:

- Cut-off/wide seal (0.3")
- External vacuum adapter



**BUSCH**  
BUSCH PUMP

	KAZE14	KAZE16	KAZE16XL	KAZE16XLD
<b>Power</b>	120V, 960W, 8A, 5-15P	120V, 1600W, 17A, 5-15P	120V, 1760W, 17A, 5-20P	120V, 1760W, 17A, 5-20P
<b>Chamber size (L x W x H)</b>	14.6" x 14" x 6"	14.6" x 16.5" x 7"	18" x 16.5" x 7"	16" x 16.5" x 7"
<b>Seal bar</b>	14"	16.5"	16.5"	2 x 16.5"
<b>Pump speed</b>	10 m <sup>3</sup> h	19 m <sup>3</sup> h	25 m <sup>3</sup> h	25 m <sup>3</sup> h
<b>Machine cycle</b>	35 sec	30 sec	30 sec	30 sec
<b>Dim. (L x W x H)</b>	21.4" x 17.8" x 18"	20.6" x 19.3" x 18.3"	24" x 19.3" x 18.5"	24" x 19.3" x 18.5"
<b>Net weight</b>	79 lbs	126 lbs	150 lbs	159 lbs
<b>Ship dimensions</b>	28.3" x 22.8" x 22.4"	28.3" x 22.8" x 25.6"	28.3" x 22.8" x 25.6"	28.3" x 22.8" x 25.6"
<b>Ship weight</b>	108 lbs	143 lbs	176 lbs	185 lbs

Optional add-ons can be installed at purchase or shipped separately.

\*Liquid Control: Prevents liquids from boiling during the vacuum process. As soon as the boiling point is detected, the vacuum process stops, and the bag is sealed. With no loss of moisture, the product, pump and vacuum chamber are equally protected.

\*\*Sensor Control: The vacuum process will end as soon the pre-set percentage has been reached.



Warranty: 1 year parts and labor, 3 years parts (excludes pumps, Teflon seal tape and gaskets)

# ATMOVAC™

## KAZE14

SEAL BAR  
CONFIGURATION

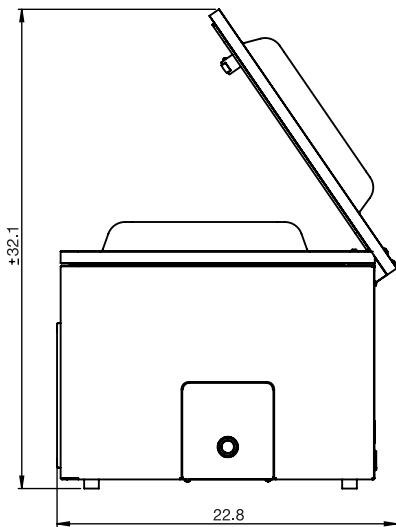
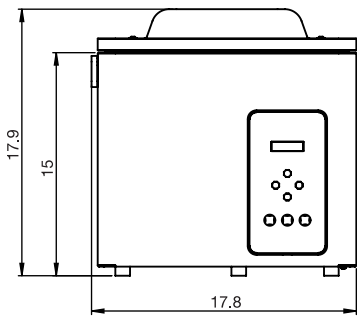
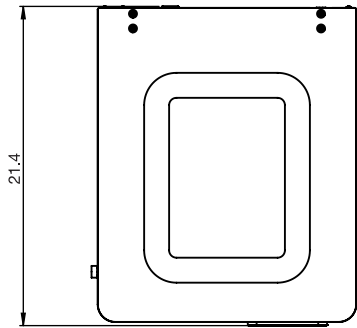
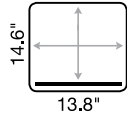

## KAZE16

SEAL BAR  
CONFIGURATION

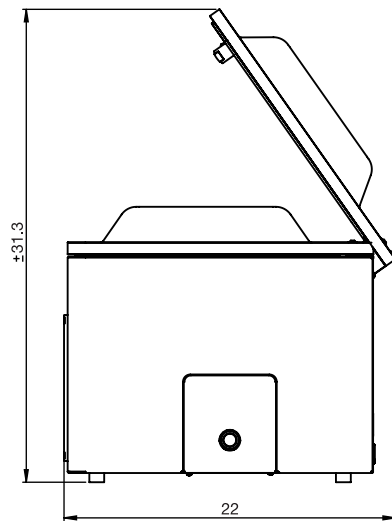
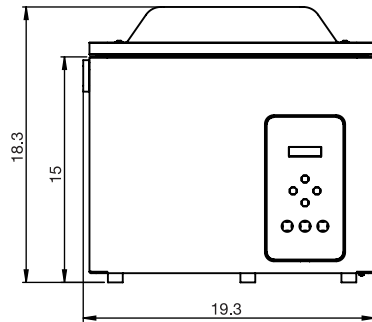
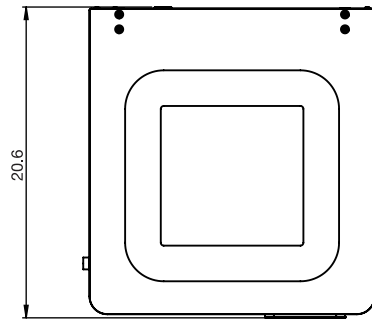
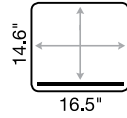

## KAZE16XL

SEAL BAR  
CONFIGURATION

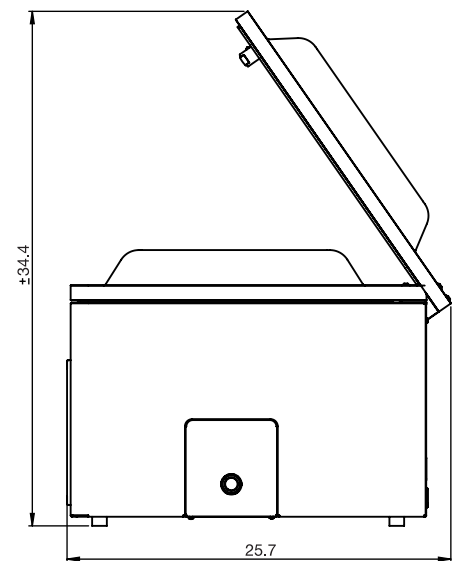
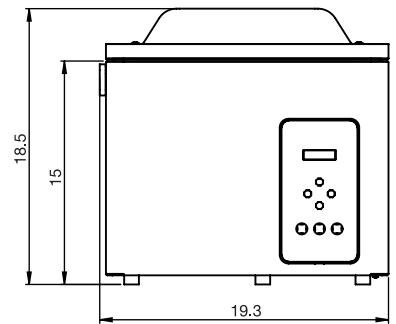
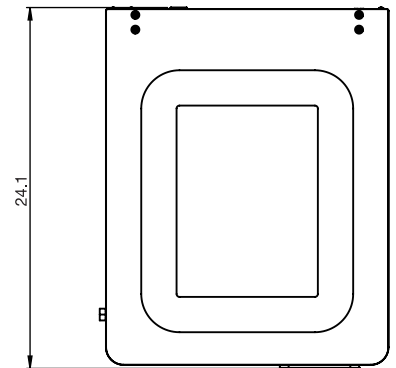
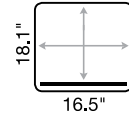

## KAZE16XLD

SEAL BARS  
CONFIGURATION

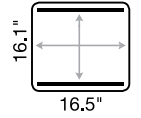

Dimensions expressed in inches