

ATMOVAC

A COMPLETE RANGE OF SOUS-VIDE COOKING SOLUTIONS

SV-96
MADE IN CHINA

THERMAL IMMERSION CIRCULATORS FOR SOUS-VIDE

With volume capacity from 25 liters (6.6 gallons) to 60 liters per unit (15.6 gallons) our ATMOVAC units will deliver precise temperature control over time in all conditions.

- Precise temperature and time control
- Adapts to a variety of containers.
- Sous-Vide cooking or Precise Rethermalization in Cook and Chill processes
- Perform pasteurization processes for maximum shelf life and sale opportunity
- No direct contact with air or water extends life of foods and provides maximum safety
- Save on energy consumption compared to oven or gas stove



**ALSO AVAILABLE
FROM ATMOVAC**



SV-120
MADE IN CHINA



SV-310
MADE IN CHINA



SOFTCOOKER XP 120/230
MADE IN ITALY

ATMOVAC

SV-96	
POWER	120V, 900W, 7.5A
NEMA	5-15P
MINIMUM WATER LEVEL	4.25"
MAXIMUM WATER LEVEL	6.5"
MAXIMUM VOLUME CAPACITY	8 Gal (30L)
WATER CIRCULATION RATE	1.2 Gal/min (4.5 L/min)
TIMER RANGE	5 mins - 99 hrs
TEMPERATURE RANGE	5 - 95°C
	41 - 203°F
TEMPERATURE VARIANCE (+/-)	0.1°C
	0.1°F
AUTO SHUT-OFF	NO
DIMENSIONS (L X W X H)	6.25" x 4" x 13.25"
NET WEIGHT	4 lbs
SHIPPING DIMENSIONS (L X W X H)	15.75" x 15" x 14.75"
SHIPPING WEIGHT	11 lbs

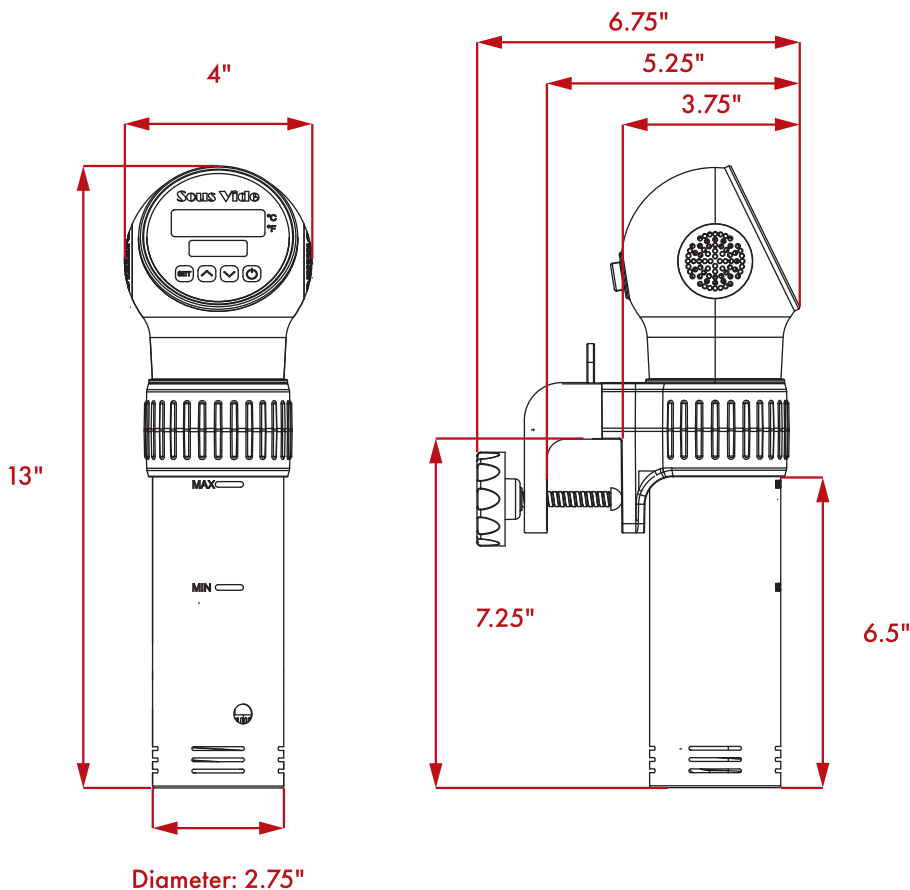

FEATURES:

- Temperature and Time Controls
- Adjustable fixed clamp
- Removable filter for easy cleaning
- IPX7 certified waterproof

SAFETY FEATURE:

- Dry-Run Protection
- Element protective cell
- Protection against overvoltage and overheating

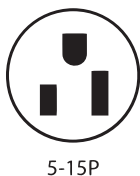

V2.12.2021